

A preparatory study of appropriate fire test procedures for sprinkler systems on ro-ro cargo decks

Magnus Arvidsson
Jukka Vaari (VTT)

A preparatory study of appropriate
fire test procedures for sprinkler
systems on ro-ro cargo decks

Abstract

A preparatory study of appropriate fire test procedures for sprinkler systems on ro-ro cargo decks

Although fires on ro-ro cargo decks historically are rare they can result in a large property loss if the fire is not manually extinguished or if the fixed fire-fighting system fails to control it. Traditionally, ro-ro cargo decks where people have access (“Special category spaces”) are equipped with water spray systems designed and installed in accordance with the prescriptive requirements given in IMO Resolution A.123(V).

The primary and short term objective of the project was to provide a basis for the development of fire test sources and fire test procedures used to establish the performance of a water spray system in accordance with Resolution A.123(V). The completion of this task would allow “equivalent” fire protection systems to be established, having present day performance.

Within the project, two different fire test sources were suggested: one simulating a typical fire in the passenger compartment of a passenger car, the other a fire in the cargo of a freight truck or semi-trailer.

This report discusses the desired basic requirements for the fire scenarios and fire test procedures for ro-ro decks on ships. Efforts have been made to ensure that the fire scenarios are realistic, but still achievable and that the fire test procedures will be as repeatable and reproducible as possible.

The report also provides background information and some illustrating photos.

Key words: Sprinkler systems, water mist systems, ships, ro-ro decks

**SP Sveriges Provnings- och
Forskningsinstitut**
SP Rapport 2006:02
ISBN 91-85303-81-X
ISSN 0284-5172
Borås 2006

**SP Swedish National Testing and
Research Institute**
SP Report 2006:02

Postal address:
Box 857,
SE-501 15 BORÅS, Sweden
Telephone: +46 33 16 50 00
Telex: 36252 Testing S
Telefax: +46 33 13 55 02
E-mail: info@sp.se

Contents

Abstract	2
Contents	3
Preface	4
Sammanfattning (Summary in Swedish)	5
1 General	7
1.1 Introduction	7
1.2 Previous projects	8
1.3 The scope of the project	9
1.4 The content of this report	9
2 Fire test procedures for ro-ro decks carrying freight trucks	10
2.1 Basic requirements of the fire test source	10
2.2 The geometrical dimensions	10
2.3 The fire load and the targets	12
2.4 Instrumentation	18
2.5 Fire test hall and environmental conditions	19
2.6 Fire test procedures	19
2.7 Acceptance criteria	20
3 Fire test procedures for car carriers	21
3.1 Basic requirements of the fire test source	21
3.2 The geometrical dimensions	21
3.3 The fire load and the targets	22
3.4 Instrumentation	22
3.5 Fire test hall and environmental conditions	23
3.6 Fire test procedures	23
3.7 Acceptance criteria	23
4 Summary and conclusions	24
4.1 The scope of the project	24
4.2 Fire test procedures for ro-ro decks carrying freight trucks	24
4.3 Fire test procedures for car carriers	24
4.4 Flowing fuel fire scenario	25
5 The continuation of the project	26
References	27
Appendix A: Background information	
Appendix B: Illustrating photos	
Appendix C: Freight truck test fire source (drawing)	
Appendix D: Freight truck test fire source – wood supports (drawing)	
Appendix E: Passenger car test fire source (drawing)	

Preface

The project was financed by VINNOVA, the Swedish Governmental Agency for Innovation Systems (project number 2005-00928). The internal SP project number was BRs 6115. The project involved preliminary fire tests conducted at the fire test laboratory at VTT, using the prototype fire scenarios discussed in the report. The tests were financed by TEKES, the National Technology Agency of Finland and Marioff Corporation Oy but are not described within the report.

The project was conducted in close co-operation with a group consisting of the authors of this report and the following persons:

Stefan Gordin	Marioff Corporation Oy
Maarit Tuomisaari	Marioff Corporation Oy
Anders Tosseviken	Det Norske Veritas
Margaret Simonson	SP Swedish National Testing and Research Institute, Department of Fire technology

The input from this group is gratefully acknowledged.

All photos, except where noted, by the author.

Sammanfattning (Summary in Swedish)

Brand på ro-ro däck är långt ifrån så vanligt förekommande som brand i fartygsmaskinrum, men det inträffar regelbundet.

För ro-ro däck där passagerarna har tillträde vid lastning och lossning används idag pratiskt taget bara en typ av fast släcksystem, vattensprinklersystem. Dessa system dimensioneras och installeras enligt kraven i IMO Resolution A.123(V). För andra typer av ro-ro lastutrymmen, där personsäkerhetsrisken är lägre - eftersom passagerare inte har tillträde - används normalt koldioxidsystem. Men andra typer av intergassystem, vattensprinklersystem eller lättskumssystem kan också användas.

De nuvarande kraven för vattensprinklersystem i IMO Resolution A.123(V) härrör sig från 1967. Flera projekt, finansierade av bland annat Brandforsk, har visat att systemen inte är anpassade till dagens behov utan troligen underdimensionerade för många av de bränder som kan uppstå på ett ro-ro däck. Det bör tilläggas att det även finns en brandprovningmetod och installationsföreskrifter för ”alternativa” system. Dessa krav har antagits av IMO som en alternativ möjlighet genom IMO MSC/Circ. 914. I dagsläget finns dock inga system på marknaden som möter dessa krav.

Den **långsiktiga** målsättningen med projektet är att främja användningen av mer effektiva vattenbaserade släcksystem på ro-ro däck ombord på fartyg än de som stipuleras av IMO Resolution A.123(V). Effektivare system kan åstadkommas med automatiska system, genom att öka vattentätheten, blanda skumvätska till vattnet eller genom att använda system av typen ”vattendimma”. Den långsiktiga målsättningen med projektet är således att ta fram föreskrivande krav som ersätter IMO Resolution A.123(V), men med en betydligt högre säkerhetsnivå än dagens krav och att ta fram en brandprovningmetod som ersätter IMO MSC/Circ. 914.

Projektet **mer kortsiktiga** målsättning, som omfattas av denna rapport, är att ta fram ett första förslag, ett diskussionsunderlag, för hur man kan brandprova nya ”alternativa” system och vilka krav man bör ställa på dessa. Självfallet skall metoden även användas för att utvärdera effektiviteten för befintliga, godkända sprinklersystem.

Sökord: Sprinkler, fartyg, ro-ro däck, brand

1 General

1.1 Introduction

Fires on ro-ro cargo decks are rare and historically they have not represented a major risk for passenger and crew. However, the property loss can be large if the fire is not manually extinguished or if the fixed fire-fighting system fails to control the fire and there are cases where a fire has spread throughout the ship [1].

For ro-ro cargo spaces not capable of being sealed or being considered as “special category spaces”, i.e. an enclosed space on a deck intended for the carriage of motor vehicles with fuel in their tanks for their own propulsion and to which the passengers have access, SOLAS Chapter II-2, Regulation 20 requires that the deck shall be protected with an approved deluge type sprinkler system. Other types of fixed fire-fighting systems are not allowed, due to the safety concerns for the passengers or because the limited integrity of the compartment would make gas extinguishing systems unsuccessful.

Detailed installation requirements related to sprinkler systems for special category spaces are given in IMO Resolution A.123(V) [2]. These requirements are described in principle below. Sprinkler systems equivalent to systems specified in Resolution A.123(V) may be used. Such systems shall comply with the installation guidelines and fire test procedures in MSC/Circ. 914 [3]. The installation requirements for such equivalent systems are in principle identical with the requirements in Resolution A.123(V) and are summarized below.

1.1.1 The requirements in IMO Resolution A.123(V)

Resolution A.123(V) was issued in 1967, and the technical background material was probably based on fire tests [4] conducted in Denmark in the early 1960's.

The sprinkler system should normally cover the full breadth of the vehicle deck and may be divided into sections provided that they are at least 20 m (66 ft). However, in ships where the vehicle deck is subdivided with longitudinal “A” class divisions forming boundaries of staircases, etc., the breadth of the sections may be reduced accordingly.

The section valves for the system should be situated in an easily accessible position adjacent to, but outside the protected space.

A pump or pumps other than the ship's mandated fire pumps should provide the water supply for the system. The capacity of the pumps(s) should be sufficient to provide water at the required pressure to all nozzles on the vehicle deck or at least two sections.

The pump(s) should be capable of being brought into operation by remote control (which may be manually activated) from the position at which the section valves are positioned.

The average discharge density shall equal 3,5 (L/m²)/min for spaces with a deck height not exceeding 2,5 m and 5 (L/m²)/min for deck heights in excess of 2,5 m. The water pressure should be sufficient to ensure an even distribution of water.

1.1.2 The requirements in MSC/Circ. 914

MSC/Circ. 914 was issued in 1999 and contains installation guidelines and fire test procedures for alternative, fixed, water-based fire-fighting systems for special category spaces. Regarding component tests, reference is made to MSC/Circ. 668, as amended by MSC/Circ. 728.

The fire test procedures are divided into two parts, one part where the fire suppression and control capabilities of the system should be tested, the other part where the area of operation of the system should be determined.

The fire source for the first part consists of a simulated freight truck with targets simulating adjacent trucks. Fire is initiated by a heptane ('gasoline') pool fire positioned under the freight truck. Ceiling surface temperatures are measured as well as temperatures under the freight truck, thereby simulating the fire exposure to the fuel tanks.

The test results are judged to be acceptable if the temperatures measured under the freight truck and at the ceiling is reduced to certain levels. In addition, the target arrays should not ignite.

The area of operation tests is intended to establish the area of operation of wet, dry-pipe and pre-action systems. The tests are conducted using a large open pool fire with heptane ('gasoline') and the numbers of nozzles that operate are determined. The area of operation is determined by multiplying the number of nozzles that operate in the test with the coverage area of the individual nozzles.

The capacity of the water supply to the system should be based on the total simultaneous coverage of the most hydraulically demanding 280 m² area or four times the area of operation determined by the test described above, whichever is greatest.

No specific fire tests for pure car carriers are given in MSC/Circ. 914.

1.2 Previous projects

Since the mid-1990's, several projects [5, 6, 7] have been conducted, both aiming at investigating the fire hazards on ro-ro decks and cargo spaces, the consequences of such a fire, and the most appropriate fire protection. The large-scale fire test reported in [6] was documented in a video [8] and the test set-up that was used formed the basis for the fire test procedures in MSC/Circ. 914.

The influence of the ventilation conditions has been investigated in model scale [9]. These tests have shown that a fire on a vehicle deck can be very large before it becomes ventilation controlled, due to the large volumes associated with ro-ro cargo decks. For decks that typically are 180 m in length, tests and calculations show that a fire can grow to almost 80 MW before the fire becomes ventilation controlled. The average gas temperature is high, of the order of 250°C to 300°C and consequently the temperature and heat radiation directly above the fire can be extremely high. There is an apparent risk for fire spread through the conduction of heat to decks above. As the maximum fire size is a function of the volume of the deck, sectioning of the deck can be an efficient way to limit the size of a fire.

A fire during loading or unloading may be critical as a fire potentially could become very large before being controlled by ventilation conditions.

1.3 The scope of the project

The primary and short term objective of this project has been to provide a basis for the development of fire test sources and fire test procedures used to establish the performance of a water spray system designed and installed in accordance with Resolution A.123(V). The completion of this task will allow “equivalent” fire protection systems to be established, having present day performance.

The secondary and long term objective of the project has been to improve the performance of the Resolution A.123(V) systems and associated “equivalent” systems. This task is especially important for special category spaces and cargo spaces carrying freight trucks, tourist buses, passenger and cargo trains, etc. This will require more stringent fire test procedures with fire scenarios representing a higher hazard level. This document discusses the choice of a representative high hazard commodity.

The third objective of the project has been to establish a fire test source and fire test procedures for pure car carriers, i.e. where the fire hazard is represented by new or used passenger cars, loaded very close together with minimal liquid fuel in the tank for self-propulsion.

1.4 The content of this report

Within the project, two different fire test sources are suggested: one fire test source simulating a typical fire in the passenger compartment of a passenger car, and the other a fire in the cargo of a freight truck or a semi-trailer.

This document discusses the desired basic requirements of the fire scenarios and appropriate fire test procedures. Efforts have been made to ensure that the fire scenarios are realistic, but still achievable, and that the fire test procedures will be as repeatable and reproducible as possible.

This report also provides background information and some illustrating photos.

2 Fire test procedures for ro-ro decks carrying freight trucks

2.1 Basic requirements of the fire test source

A fire test source representing fires in a freight truck or a semi-trailer would, under ideal conditions, need to:

- Simulate the geometrical dimensions of a freight truck or a semi-trailer and the typical distances between the vehicles on a ro-ro deck,
- Represent typical cargoes¹ carried on freight trucks,
- Provide fire scenarios that are as repeatable as possible,
- Produce as limited an amount of toxic gases as possible,
- Be simple and easy to store and set up,
- Be easily available,
- Be well-established and accepted, and,
- Be reasonably inexpensive.

A discussion of a fire test source that meet these requirements and an appropriate fire test procedures is given below.

2.2 The geometrical dimensions

2.2.1 Background information

The geometrical dimensions of freight truck vehicles in Europe are regulated in EU Directive 96/53/EC which amends the maximum authorised dimensions and also applies to vehicles used in national traffic. The maximum vehicle length is 18,75 m and the maximum width is 2,55 m (2,60 m for refrigerated vehicles). The restrictions on height (4,0 m) and weight (40 tonnes) authorised for international traffic are not extended to national traffic.

Sweden and Finland have an exception from the directive which allows freight trucks with trailers to be a maximum 25,25 m long. In addition, it is common that the freight trucks are up to 4,50 m high. Typical freight truck and trailer combinations used in these countries are shown in Figure 1.

¹ Swedish statistics from SIKA/SCB identify 24 different groups of commodities commonly transported on Swedish roads. The combustible commodity can be apportioned by mass ratio into four different categories: cellulosic materials (42 % by mass), miscellaneous commodity including packaging materials (28 %), food products (17%) and oil products (13 %).

The two largest categories include cellulosic materials and miscellaneous commodities with packaging materials. The packaging material is usually either cardboard cartons or plastics. The statistics do not divide the miscellaneous commodity with packaging material into cellulosic material and plastics. Discussions with professional goods transport agents in Sweden indicate that a mass ratio of 80 – 85 % cellulosic material with 15 – 20 % plastics is a reasonable division between these two categories.

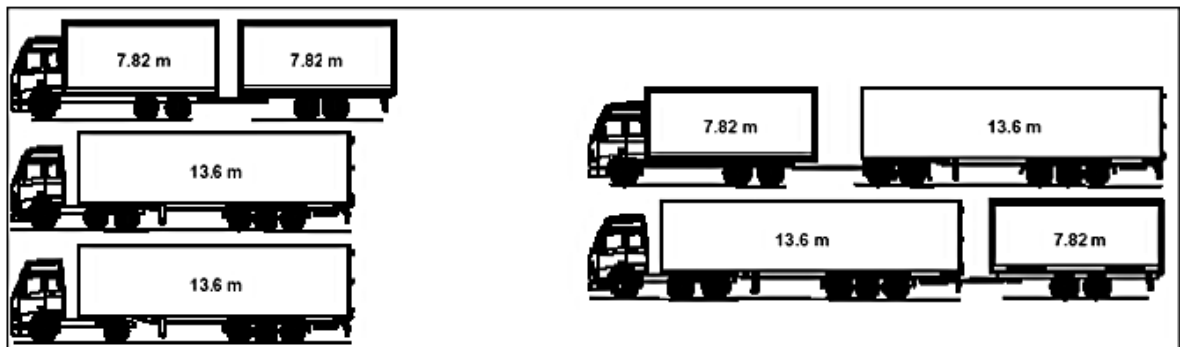

Figure 1 Typical freight truck and trailer combinations in Sweden and Finland [10].

Trailers covered by tarpaulins are common in Europe, but not as common in the Nordic countries, due to the climate. In these countries solid boxes are used. The walls and ceiling of these boxes are usually made from a sandwich panel with outer sides of 2 mm plastic sheets and a core made from either plywood, polyurethane (PU) or expanded polystyrene (EPS). The overall thickness is typically 20 mm. The parts are glued together and then put into a framework of aluminium profiles. For the transportation of food or other products that require a lower than ambient temperature, the walls and ceiling of such a box are usually up to 45 – 55 mm thick with a core of expanded polystyrene (EPS).

Freight trucks for shorter distance transportations usually have a door at the rear, with a lift to load and unload the cargo. Freight trucks and trailers for long haulage transports have in addition, doors on one or both sides, for easier access to the cargo.

2.2.2 The proposed fire test source

Refer to the drawing in Appendix C. The drawing shows the ‘freight truck’ or ‘semi-trailer’ model, where fire ignition will take place with two targets on either side.

A platform with outer dimensions of 10,0 m by 2,6 m should be used. The vertical distance measured from floor level to the deck formed by the platform should be 1,3 m. The platform should be constructed from non-combustible material, such as solid steel plates or non-combustible boards.

The ‘imaginary’ outer dimensions of the ‘freight truck’ or ‘semi-trailer’ model are indicated in the drawing. The overall width equals 2,6 m and the overall height 4,0 m, i.e. the maximum width and height allowed in the European Union. The model could be covered by a tarpaulin with or without a solid roof. However, for reasons of simplicity, it is suggested that no tarpaulin is used. The influence of the use of a solid roof or not would need to be investigated through fire testing. A solid roof will prevent water from reaching the seat of the fire. On the other hand, the severity of the fire may be reduced.

The cargo on the platform should consist of a stacked commodity on wooden pallets². The commodity cartons that are shaded in the drawing constitutes the primary fire load, the other cartons constitutes the secondary fire load, see the discussions below.

² Standard four-way, nine-block, EUR wooden pallets should be used. The pallets are non-perimetric, 1200 mm by 800 mm pallets (i.e. no bottom base boards in the 800 mm direction). The overall measured pallet height is nominally 145 mm. The pallets are made from softwood, i.e. spruce or fir.

For reasons of stability, the stacks of commodity need to be supported. This could be made by using wood supports as shown in the drawing in Appendix D. The supports will prevent individual cardboard cartons from falling or leaning into the flue spaces between the stacks, thereby blocking the spread of fire as well as the direct access of water. Improved stability of the commodity will improve the repeatability of the fire development and the fire test results. The supports should be made from 45 mm by 45 mm spruce or fir, attached directly to the wood pallets using wood screws (preferably) or nails.

The horizontal distance between the piles of commodity in the lengthwise direction of the platform, i.e. the longitudinal flue space, is 100 mm. The transversal flue spaces are 200 mm, as measured from the sides of the cardboard cartons. The free space of the transversal flue spaces is, due to the wood supports described above, 110 mm.

An alternative way of ensuring the stability of the commodity could be to use a steel rack, having the top commodity on beams. This would make the overall height of the fire load slightly higher and would introduce a horizontal gap between the commodity pallet loads.

2.3 The fire load and the targets

2.3.1 The primary fire load

The geometrical dimensions of an actual freight truck or semi-trailer are reflected by the fire test source described above. However, the severity of the fire load can be adjusted by choosing a standard commodity having either a 'low', 'intermediate' or 'high' commodity classification. Alternative commodities that could reflect different levels of fire severity are discussed below.

The primary fire load consists of eight stacks of commodity in a 2 by 4 arrangement, as shown in the drawing in Appendix C. This would probably represent the minimum amount of commodity needed for a test.

Table 1 shows a comparison of three different 'standard' commodities when placed on regular 800 mm by 1200 mm EUR pallets. Any of these three commodities could be chosen as the primary fire load, dependent on the desired severity of the fire test source.

The EUR Standard Plastic commodity is similar in design to the FM Global Standard Group A Plastic Commodity, a commodity that is considered a high hazard commodity, and regularly used for large-scale sprinkler tests in the USA. This commodity is probably the most well-established international 'standard' commodity.

The EUR Standard Plastic commodity consists of empty polystyrene cups without lids, placed upside down (i.e. open end down), in compartmented cartons, 120 cups per carton. The cartons measure 600 mm by 400 mm by 500 mm (L × W × H) and are made from single-wall, corrugated cardboard. Eight cartons are placed on each pallet.

When compartmented, the cartons are divided into five layers by corrugated sheets, with each layer divided into 24 compartments by overlocking corrugated cardboard partitions, forming a total of 120 compartments where the plastic cups are placed. The commodity therefore contains 960 polystyrene cups per pallet load.

Plastic constitutes approximately 42% (by weight) of the EUR Standard Plastic commodity, if the weight of the wooden pallet is included in the estimation.

The EUR Standard Category II+ commodity contains 30 plastic cups per carton, instead of 120 cups. This corresponds to 15% (by weight) of plastics, if the weight of the wooden pallet is included in the estimation.

The EUR Standard Category II commodity uses no plastics cups at all, only the corrugated cardboard interior.

An alternative to the standard commodities discussed above may be the use of stacks of idle wooden EUR pallets. These pallets have dimensions 1200 mm × 800 mm with an overall height of nominally 145 mm. Seven (7) pallets on top of each other would provide a height of 1015 mm, i.e. similar to the height of the standard commodities. The pallets should, as the standard commodities, be placed on a bottom pallet, i.e. ‘one pallet load’ would actually consist of eight pallets on top of each other. The nominal weight of one pallet is 20 kg, however, there could be a certain variation in weight between individual pallets as well as from different makes.

Table 1 Weight and measures of three different ‘standard’ commodities when placed on regular 800 mm by 1200 mm EUR pallets compared to the weight and measures of ‘one pallet load’ of idle wooden pallets. Note: The weight of the pallet is not included.

	EUR Standard Plastic	EUR Cat. II+	EUR Cat. II	Idle wooden pallets
Measures (pallet not included)				
Size of individual cartons [mm]	600 × 400 × 500	600 × 400 × 500	600 × 400 × 500	--
No. of cartons on each pallet	8 pcs	8 pcs	8 pcs	--
Arrangement of cartons	2 × 2	2 × 2	2 × 2	--
Size of pallet load, exc. pallet [mm]	800 × 1200 × 1000	800 × 1200 × 1000	800 × 1200 × 1000	800 × 1200 × 1015
Pallet area [m ²]	0,96	0,96	0,96	0,96
Total surface area of pallet load [m ²]	5,92	5,92	5,92	5,98
Total volume of pallet load [m ³]	0,96	0,96	0,96	0,97
No. of plastic cups				
Per individual carton	120	30	None	--
Per pallet load	960	240	None	--
Weights (pallet not included)				
Total weight of one pallet load [kg]	43,2	24,0	17,7	7 × 20 = 140
Average weight of individual cup [g]	28,2	28,2	--	--
Number of cups	960	240	--	--
Total weight of plastic per pallet load [kg]	27,1	6,77	--	--
Plastic density per pallet load [kg/m ³]	28,2	7,05	--	--

Table 2 provides an estimation of the fire load per pallet load of the three ‘standard’ commodities discussed above.

Table 2 An estimation of the fire load, per pallet load, of the three ‘standard’ commodities’ compared to ‘one pallet load’ of idle wooden pallets.

	EUR Standard Plastic	EUR Cat. II+	EUR Cat. II	Idle wooden pallets
Plastics				
Total weight [kg]	27,1	6,8	--	--
Heat of combustion [MJ/kg]	30	30	--	--
Energy content [MJ]	<u>813</u>	<u>204</u>	--	--
Cellulose (cardboard cartons or wood)				
Total weight [kg]	≈17	≈17	≈17	7 × ≈20 = 140
Heat of combustion [MJ/kg]	15	15	15	15
Energy content [MJ]	<u>255</u>	<u>255</u>	<u>255</u>	<u>2100</u>
Wooden pallet				
Total weight [kg]	≈20	≈20	≈20	≈20
Heat of combustion [MJ/kg]	15	15	15	15
Energy content [MJ]	<u>300</u>	<u>300</u>	<u>300</u>	<u>300</u>
Fire load (per pallet), incl. pallet [MJ]	1368	759	555	2400

Given the fire load in Table 2, an estimation of the total fire load of a freight truck with a trailer can be made. Long distance freight truck vehicles within the European Union generally have 33 or 34 load spaces (see the background information given in Appendix A) where a truck load unit is equivalent to the dimensions of a EUR pallets, i.e. 1200 mm × 800 mm.

The total fire load, for the three different ‘standard’ commodities and idle wooden pallets, is therefore:

- EUR Standard Plastic commodity: (2 pallet loads × 34 load spaces) × 1368 MJ ≈ 93 GJ.
- EUR Cat. II+ commodity: (2 pallet loads × 34 load spaces) × 759 MJ ≈ 52 GJ.
- EUR Cat. II commodity: (2 pallet loads × 34 load spaces) × 555 MJ ≈ 38 GJ.
- Idle wooden pallets: (2 pallet loads × 34 load spaces) × 2400 MJ ≈ 163 GJ

SP Report 2002:03 presents [11] a number of comparison fire tests using different combustible products, when tested in accordance with Nordtest standard NT Fire 049 [12]. Results for the three ‘standard’ commodities and idle wooden pallets are included in the combustible products reported.

The fire tests reported involved arranging a four pallet-load of the particular commodity in a rack storage arrangement. In each test, four pallet loads of commodity were placed in a 2 by 1 by 2 configuration, see Figure 2. Note that ‘large’ wooden pallets sized 1200 mm by 1000 mm were used and that the commodity therefore consisted of a total of 40 individual cardboard cartons.

A water applicator consisting of a matrix of spray nozzles was arranged over the commodity and the entire set-up was positioned underneath a calorimeter to facilitate the measurement of the Heat Release Rate (HRR). The commodity was ignited at the centreline of the flue space, and water was applied when the fire reached a convective heat release rate of 2 MW. At which point, the fire normally involved the whole upper tier of the commodity.

Three such trials were conducted for each type of commodity, at three different rates of water application. With the data obtained from the tests, classification criteria for the four main commodity categories according to the European sprinkler standard, EN 12845 (categories I, II, III and IV), can be established.

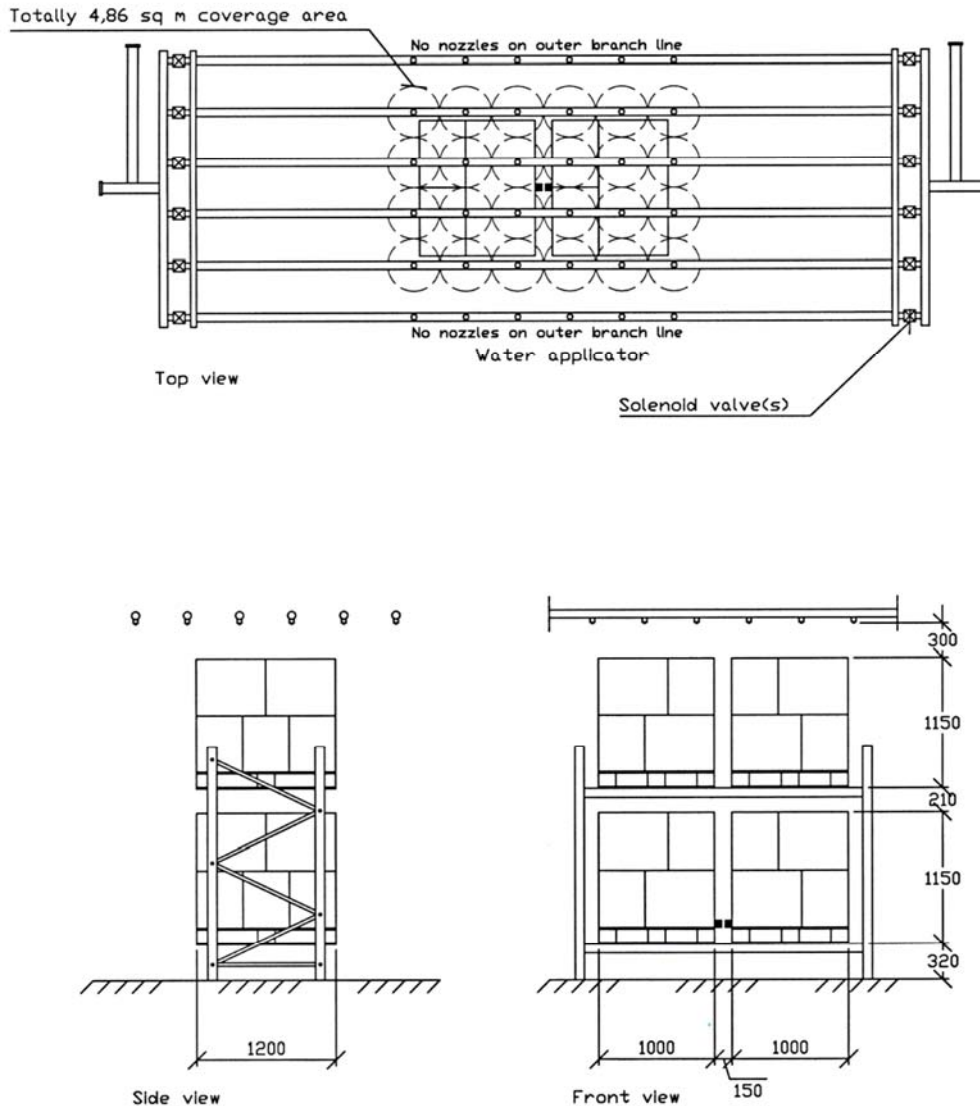

Figure 2 A schematic drawing of the test set-up used in Nordtest Fire 049. The Industry Calorimeter is not shown.

The graph in Figure 3 shows the Heat Release Rate histories for the three ‘standard’ commodities discussed above along with two stacks of idle wooden pallets. The nominal water discharge density was 5,0 mm/min. The graph provides an understanding of the relative severity of the four commodities.

Not surprisingly, the EUR Standard Plastic commodity has the most severe fire characteristics of the three standard commodities, due to its larger content of plastics. However, all three commodities develop very rapidly when the fire propagates in the outer layer of cardboard carton, up the vertical flue space between the two stacks of commodity.

The fire growth of the idle wooden pallets is not as rapid. The fire intensity gradually builds up to its peak level, despite the application of water, and the fire size does not decrease until the combustibles start to become consumed.

For all four tests, virtually all the combustible material was consumed. However, the total amount (mass) of the idle wooden pallets is three to four times higher compared to the standard commodities. This corresponds to a significantly longer burn time.

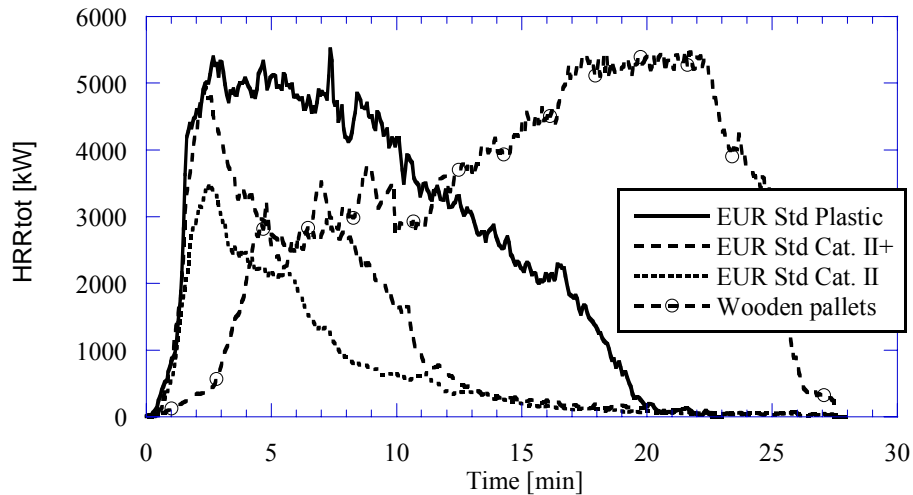

Figure 3 The relative severity of the three 'standard' commodities and idle wooden pallets. The nominal water discharge density was 5,0 mm/min.

Figure 4, shows the results from three tests using the EUR Standard Plastic commodity (only) at three different water discharge densities, 5,0 mm/min, 7,5 mm/min and 10,0 mm/min, respectively. The graph provides an understanding of the influence of water discharge density for this particular commodity. The higher the flow rate the more the fire is suppressed. For the test at 10,0 mm/min, approximately 72% of the goods remained undamaged after the test, for the lower discharge densities, all or almost all of the combustibles were consumed.

It should be noted that the nominal water discharge densities used in the tests are not directly comparable to the discharge densities used when designing actual sprinkler systems. The data should rather be used as a relative comparison of the fire suppression characteristics relative to the different commodities.

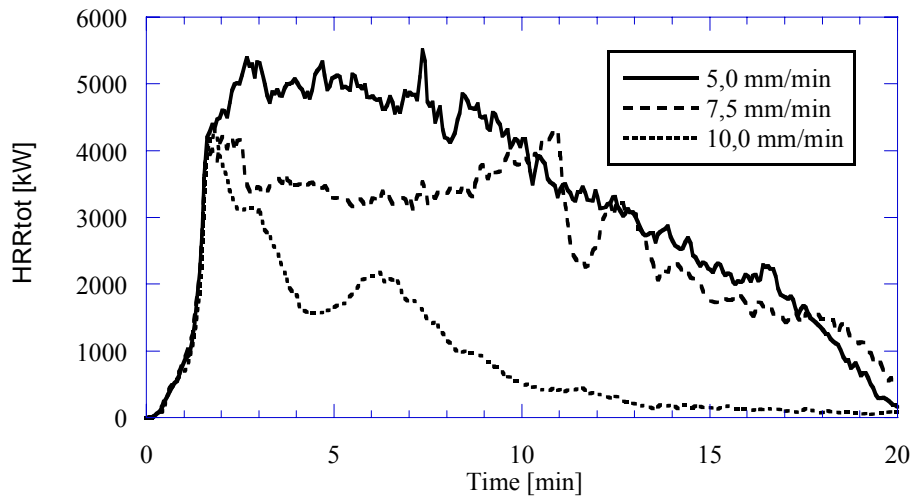

Figure 4 The Heat Release Rate histories for the EUR Standard Plastic commodity at three different nominal water discharge densities, 5,0 mm/min, 7,5 mm/min and 10,0 mm/min, respectively.

From Figure 4 it may also be concluded that the initial fire development of the commodity is very repeatable. This exceptional test-to-test repeatability has also been determined for the EUR Cat. II+ and EUR Cat. II commodity, respectively, and is highly desired for the fire test source discussed here.

Figure 5, shows the results from three tests using idle wooden pallets at three different water discharge densities, 5,0 mm/min, 7,5 mm/min and 10,0 mm/min, respectively. Note the different time-scale from that of Figure 4. As expected, a higher water flow rate provides improved fire suppression. For the two lower water application rates it is noteworthy that the fire initially was suppressed or controlled at the start of the water application, but re-developed.

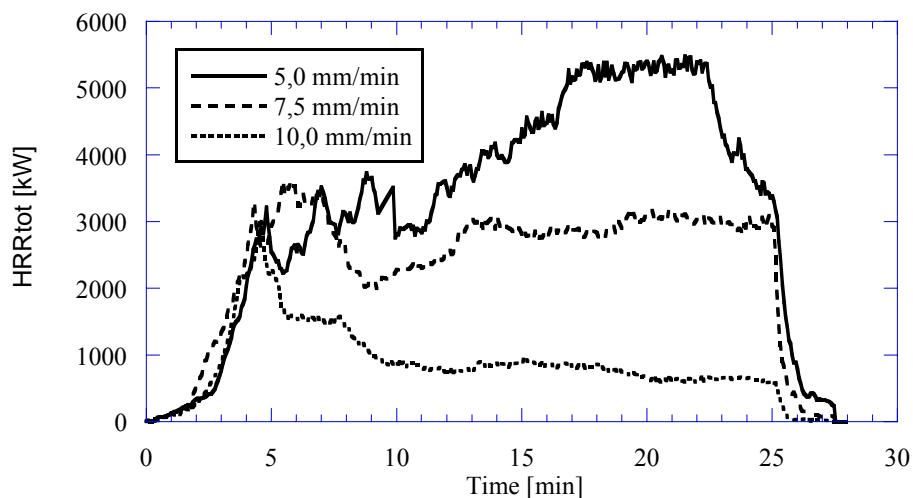

Figure 5 The Heat Release Rate histories for tests with idle wooden pallets at three different nominal water discharge densities, 5,0 mm/min, 7,5 mm/min and 10,0 mm/min, respectively.

At 5,0 mm/min, approximately 85% of the combustible material was consumed, at 7,5 mm/min approximately 65% and at 10,0 mm/min only 15% was consumed. The initial fire growth is reasonably repeatable.

2.3.2 The secondary fire load

The secondary fire load, (see the drawing of Appendix C) is intended to act as an indicator of the fire spread in the length-wise direction.

This commodity could consist of a similar commodity to that in the primary fire load, empty cardboard cartons or, alternatively, the commodity may not be needed at all, all dependent on the desired pre-burn time and the performance of the tested system. The type of commodity for the secondary fire load, or indeed its necessity at all, needs to be determined in pre-normative fire tests.

2.3.3 The targets

The intention of the ‘targets’ on either side of the freight truck model is to be able to determine if and when the fire spreads to adjacent freight trucks. This is a measure of the performance of the tested system.

The targets could be quite simple, constructed using vertical combustible boards made of plywood or chipboard. It is probably sufficient that the overall length and height of the boards covers the length and the height of the primary fire load. The top end of the boards should be aligned with the top of the imaginary height of the freight truck.

The targets may also consist of “screens” with instrumentation to measure temperature and heat radiation. That solution is a little more complex, but provides much better information concerning the performance of the system than just “pass” or “fail” and is therefore preferable.

2.4 Instrumentation

The ceiling surface and gas should be measured using 0,5 mm wire thermocouples and Plate Thermometers. The Plate Thermometer is a well-known instrument used for temperature control of furnaces for fire testing of building products or thermal measurements during fire tests. It has been developed at SP and consists of a 100 mm by 100 mm, 0,7 mm thick plate, insulated on the backside with non-combustible material.

The design of the Plate Thermometer is such that it primarily responds to heat flux, and to a lower degree, to convection compared to a conventional wire thermocouple. A full description of the Plate Thermometer is given in references [13] and [14].

The wire thermocouples should be positioned 75 mm below the ceiling, the Plate Thermometers flush with the ceiling surface. The instruments should be positioned:

- 1) Directly above the point of ignition.
- 2) At four different locations, at a radial distance of 1,6 m from the point of ignition. The measurement positions should be located at 90° angle relative to each other.

2.5 Fire test hall and environmental conditions

2.5.1 The fire test hall

Ro-ro cargo spaces are large. Volumes around 20 000 – 30 000 m³ are not uncommon and even though many cargo spaces are enclosed, openings to the surroundings may exist. Thus, the size of a fire will not be ventilation controlled until a late stage.

The fire tests should, therefore, be conducted inside a well-ventilated fire test hall with a sufficient area and volume. The area and volume should be large enough to prevent any enclosure effects on the outcome of the tests. The enclosure effects not allowed include: accumulation of heat, smoke and water droplets within the specific test area, as well as oxygen depletion within the test hall.

Typical sufficiently large fire test halls have a floor area larger than 300 m², ceiling height over 10 m and volume larger than 5000 m³. If tests are conducted in an enclosure of smaller dimensions than indicated, it is up to the fire test laboratory to verify that enclosure effects do not influence the fire test results.

The fire test hall should have an ambient temperature of 20±5°C at the start of each test.

2.5.2 The specific test area

The fire tests should be conducted under a suspended ceiling of at least 80 m² in area with no dimensions less than 8 m. There should be at least 1 m space between the perimeters of the ceiling and any wall of the test hall.

The ceiling should be horizontal, smooth and allow for an unobstructed flow of gases across the whole ceiling. No flame screens are allowed around the perimeter of the ceiling.

The volume above the suspended ceiling, should be large enough, or be fitted with a forced ventilation system, to vent the combustion gases away from the fire zone.

The ceiling height should be set at 5,0 m in order to represent a typical deck height on a ro-ro deck.

2.6 Fire test procedures

2.6.1 Ignition of fire and pre-burn time

The fire test source should be ignited at the central flue, near the bottom of the commodity stack, using four standardised ignition sources. These igniters consist of a cube, 60 mm by 60 mm by 75 mm, made from pieces of insulating fibre board, soaked with 120 mL of heptane and wrapped in a polyethylene plastic bag prior to the test.

Systems that activate automatically should be tested with an appropriate realistic delay time, corresponding to the time delay required to start pump(s) and pressurize the system to full system operating pressure.

For manually activated system a time delay of between one to three minutes before activation is probably realistic. This delay time reflects the time required for fire

detection, start of pump(s), manual activation of the system and the water fill up time of the pipes. The delay time will ensure that the fire test source is fully involved in the fire prior to the activation.

2.6.2 Position of nozzles relative the fire test source

In order to ensure that the performance of the system tested is sufficient, independent of the position of the fire test source relative to the nozzles at the ceiling, the fire test source should be placed in three different positions.

The reference point of the fire test source is the point of ignition. Three fire tests should be conducted, with the point of ignition:

1. Directly below one water spray nozzle,
2. Between two water spray nozzles. For this case, the central, longitudinal flue space of the fire test source should be orientated perpendicular to the line between the closest nozzles, and,
3. Below four water spray nozzles.

Alternatively, the fire test source may be positioned such that position 2 and 3 are combined, by moving it such that the point of ignition is offset between two nozzles. This distance, as measured in the longitudinal direction of the freight truck model, may be $\frac{1}{4}$ the nozzle spacing or fractions of the dimensions of the commodity pallet loads. This approach will reduce the number of tests from three to two but will provide less information.

2.7 Acceptance criteria

If the performance of water spray systems installed in accordance with Resolution A.123(V) is the level of performance that is deemed acceptable for other types of systems, reference tests need to be conducted with a representative Resolution A.123(V) system. Such tests should be conducted as described within this report.

The performance of the system tested should be described in terms of temperatures recorded, fire damages of the primary as well as the secondary fire load and any fire spread to the targets.

It may be necessary to make an overall judgement of the performance of the tested system, both the tested Resolution A.123(V) and any system being considered as “equivalent” in performance to such a system. The reason is that the performance may vary considerably, depending on the location of the point of ignition relative to the nozzles at the ceiling. It may also be the case that the tested system will provide good cooling and protection of the ceiling structure, but large damages to the fire test source, and still be judged as acceptable.

3 Fire test procedures for car carriers

3.1 Basic requirements of the fire test source

A fire test source representing fires in a passenger car should:

- Simulate the geometrical dimensions of a “larger” sized passenger car, i.e. a SUV,
- Provide as repeatable a fire scenario as possible,
- Have a reasonably slow initial fire growth,
- Provide a peak Heat Release Rate of approximately 5 MW,
- Produce as limited an amount of toxic gases as possible,
- Be easily available,
- Be well-established and accepted, and,
- Be reasonably inexpensive.

A discussion of a fire test source that meets these requirements and appropriate fire test procedures is given below.

3.2 The geometrical dimensions

3.2.1 Background information

Figure 6 shows the geometrical dimensions of a Volvo XC90, an SUV (Sport Utility Vehicle), representative of this type of large passenger vehicle. These geometrical dimensions were used to model the fire test source described below.

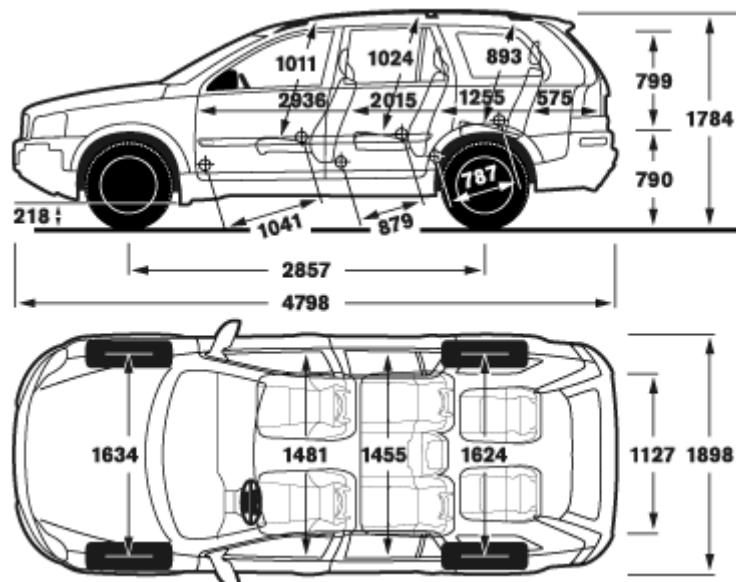

Figure 6 The geometrical dimensions of Volvo XC90, the version with seven seats [15].

3.2.2 The proposed fire test source

The proposed fire test source is a very simple model of the passenger car shown above (see to the drawing in Appendix E). The intention is to provide a fire source, with a fire load that is shielded from the direct application from the water spray, similar to the body of a car.

However, the whole of the body of the car does not need to be simulated, only the passenger area of it, i.e. not the engine compartment.

A target should be positioned on either sides of the fire test source, with the intention of determining the risk for fire spread to adjacent vehicles. The targets consists of nominally 1,5 mm steel plates, with wire thermocouples welded to the backside.

3.3 The fire load and the targets

3.3.1 The primary fire load

The suggested fire load established within the project consists of two stacks of commercially available wood pallets (soft wood), six to eight pallets in each of the stacks. The stacks are positioned under a horizontal plate made from non-combustible material, which prevents direct water spray impingement of the combustibles, similar to the body of a car.

3.3.2 The targets

The passenger car fire test set-up differs from the fire test set-up using the simulated freight truck in the respect that adjacent objects (vehicles) are not as readily combustible.

The targets on either sides of the simulated car should therefore consist of nominally 1,5 mm thick steel plates, forming a vertical and a horizontal surface, representative of the body of a car.

The transversal distance between the fire source and the targets may need to be varied dependent on the application of the system tested. For pure car carriers, the typical distance is probably approximately 200 mm, for special category spaces and conventional ro-ro decks, the typical distance is probably approximately 600 mm.

3.4 Instrumentation

3.4.1 At the ceiling above the fire test source

The ceiling surface and gas temperature should be measured using 0,5 mm wire thermocouples and Plate Thermometers as described in section 2.4.

The thermocouples should be positioned 75 mm below the ceiling, the Plate Thermometers flush with the ceiling surface. The instruments should be positioned at four different locations, at a radial distance of 1,3 m from the point of ignition. The measurement positions should be located at 90° angle relative to each other.

3.4.2 At the targets

Wire thermocouples should be welded to the backside of the steel plates that forms the targets, both on its vertical and horizontal surfaces.

3.5 Fire test hall and environmental conditions

3.5.1 The fire test hall

Tests should be conducted in principle in accordance with section 2.5.1, i.e. inside a well-ventilated fire test hall with a sufficient area and volume. However, as the fire size is smaller, the fire test hall need not necessarily be as large as that needed for the freight truck fire tests.

3.5.2 The specific test area

Tests should be conducted in principle in accordance with section 2.5.2, i.e. under a suspended ceiling.

The ceiling height should be set at 2,5 m in order to represent a typical deck height on a car carrier, with limited ceiling height, or, alternatively 5,0 m in order to represent a typical ro-ro deck.

3.6 Fire test procedures

3.6.1 Ignition of fire and pre-burn time

Fire is initiated by a 300 mm by 300 mm by 100 mm (height) fire tray positioned at the centre of the pile of wood pallets. The fire tray is filled with (for example) 2 L of heptane. The exact amount that provides proper ignition of the wood pallets needs to be determined.

The pre-burn time should be as per section 2.6.1.

3.6.2 Position of nozzles relative to the fire source

Tests should be conducted in principle in accordance with section 2.6.2, i.e. with the point of ignition in three different positions relative to the nozzles.

3.7 Acceptance criteria

Due to the construction of the fire test source, with a heavy shielding of the fire load, it is suggested that the acceptance criteria is solely based on the recorded temperatures at the ceiling and at either of the targets. It is not anticipated that damage criterion will be necessary or even applicable. Due to the shielded nature of the fire, it is likely that it will be more or less completely consumed.

4 Summary and conclusions

4.1 The scope of the project

The primary and short term objective of this project has been to provide a basis for the development of fire test sources and fire test procedures used to establish the performance of a water spray system designed and installed in accordance with Resolution A.123(V). The completion of this task will allow “equivalent” fire protection systems to be established, having present day performance.

The secondary and long term objective of the project has been to improve the performance of the Resolution A.123(V) systems and associated “equivalent” systems. This task is especially important for special category spaces and cargo spaces carrying freight trucks, tourist buses, passenger and cargo trains, etc. This will require more stringent fire test procedures with fire scenarios representing a higher hazard level. This document discusses the choice of a representative high hazard commodity.

The third objective of the project has been to establish a fire test source and fire test procedures for pure car carriers, i.e. where the fire hazard is represented by new or used passenger cars, loaded very close together with minimal liquid fuel in the tank for self-propulsion.

4.2 Fire test procedures for ro-ro decks carrying freight trucks

The fire test sources and fire test procedures described within this report represent a possibility to compare the performance of a deluge water spray system designed in accordance with IMO Resolution A.123(V) with any alternative water based (water spray or water mist system) fire protection system.

Such tests could either be conducted with a ‘low’ or ‘intermediate’ hazard commodity as the primary fire source. The EUR Standard Cat. II+ commodity discussed within the report would, with its content of plastics (15% by weight) relative to cellulose material, be representative of a statistically typical cargo.

However, for determining the performance under more severe fire conditions, a ‘high’ hazard commodity category is needed. The natural choice would be the EUR Standard Plastic commodity. This commodity is well-established and commonly accepted for fire test purposes. It should, however, be mentioned that there are other combustibles which are considered as being even more severe. Examples include, but are not limited to, products like idle wooden or plastic pallets and expanded plastics such as foam mattresses of polyurethane (PUR) or products made from expanded polystyrene (EPS).

4.3 Fire test procedures for car carriers

Fires in passenger cars are not as severe as fires in freight trucks and could be represented with a fire test source simulating parts of the body of a car. In addition, the likelihood for fire spread is lower, given that the adjacent vehicles are other passenger cars.

The transverse distance between the fire source and targets may need to be varied in the tests. For pure car carriers, the typical distance is probably around 200 mm, for special category spaces and conventional ro-ro decks, the distance is typically 600 mm.

Another difference is the amount of fuel in the fuel tanks of the cars. For pure car carriers, the amount of fuel is most likely low, for other types of vehicles decks, the amount is potentially significantly higher.

The deck height may also need to be varied, as decks not exceeding 2,5 m are common in pure car carriers while those in conventional ro-ro decks are typically higher.

4.4 Flowing fuel fire scenario

A corner stone in Resolution A.123(V) is the flowing petrol fire. This fire scenario was one of the scenarios used in the original background work for Resolution A.123(V), made in Denmark in the early 1960's.

It is suggested that some of the early Danish work be repeated and that flowing fuel fires are conducted on a floor (thin fuel layer) in order to establish the maximum flow rate that the stipulated water spray system could control. However, the technical paper [1] by DNV suggest that flowing petrol fires is not a significant fire source on ro-ro decks, which would justify giving the flowing fuel fire approach a lower priority in future standards.

5 The continuation of the project

The project documented in this report provides the basis for fire test procedures for sprinkler systems on ro-ro decks on ships, with necessary background information and rationales.

Although a large step towards such fire test procedures, additional pre-normative work including large-scale fire testing, is essential to finalise and establish the procedures. The most important questions that require further investigation include:

- **Level of exposure of the freight cargo.** For reasons of simplicity, the cargo on the freight truck or semi-trailer model is suggested to be fully exposed. This may be a more severe condition, as compared to the type of enclosed boxes commonly used in the Nordic countries, but preferable. This should be verified by fire testing.
- **System performance benchmarking.** The performance of a system designed in accordance with Resolution A.123(V) and similar systems with higher water flow rates would need to be determined. The intention would be to establish the efficiency of a system designed and installed in accordance with present day's regulatory requirements. In addition, it would also establish the design of a system having improved performance.
- **Relevant fire model HRR.** The heat release rate history of the passenger car fire source, using heat release rate calorimetry, would need to be determined.
- **Relevance of flowing petrol fire test.** Determine whether or not a flowing petrol fire should be included in the fire test procedures or not, and, if so establish the necessary technical details.

References

- 1 "Fires on Ro-Ro decks, DNV Technical Paper, Paper Series No. 2005-P018, September 2005
- 2 Resolution A.123(V), "Recommendation on fixed fire extinguishing systems for special category spaces", International Maritime Organization, London, United Kingdom, October 26, 1967
- 3 MSC/Circ. 914, "Guidelines for the approval of alternative fixed water-based fire-fighting systems for special category spaces", June 4, 1999
- 4 Fribert, F., Hansen, G., et al, "Extinction of Fire in Ships by Automatic Sprinkler Systems and Fixed Pressure Water-spraying Systems", Denmark, June 1963
- 5 Arvidson, Magnus, Ingason Haukur och Persson, Henry, "Water Based Fire Protection Systems for Vehicle Decks on Ro-Ro Passenger Ferries, Brandforsk Project 421-941, SP Report 1997:03
- 6 Arvidson, Magnus, "Large Scale Ro-Ro Vehicle Deck Fire Test, Nordtest Project 1299-96, Brandforsk Project 421-941", SP Report 1997:15
- 7 Arvidson, Magnus and Torstensson, Håkan, "En förstudie angående vattenbaserade släcksystem för lastutrymmen på fartyg, Brandforsk projekt 511-001", SP Rapport 2002:22 (in Swedish only)
- 8 Video entitled "Large Scale Ro-Ro Vehicle Deck Fire Test, Conducted at SP on the 23rd of May 1997", Swedish National Testing and Research Institute, Borås, 1997
- 9 Larsson, Ida, Ingason, Haukur and Arvidson, Magnus, "Model scale fire tests on a vehicle deck on board a ship", SP Report 2002:05, Swedish National Testing and Research Institute, Borås, Sweden, 2002
- 10 Backman, Haide and Nordström, Rolf, "Improved Performance of European Long Haulage Transport", TFK Report 2002:6E, TFK Institutet för transportforskning, 2002
- 11 Arvidson, Magnus and Lönnermark, Anders, "Commodity Classification Tests of Selected Ordinary Combustible Products, Brandforsk project 620-001", SP Report 2002:03
- 12 NT FIRE 049, "Combustible Products: Commodity Classification – Fire Test procedure", Edition 2, Approved 2005-11 (may be downloaded from <http://www.nordicinnovation.net/nordtest.cfm>)
- 13 Wickström, Ulf, "The plate thermometer - A simple instrument for reaching harmonized fire resistance tests", SP-REPORT 1989:03, Swedish National Testing and Research Institute, Borås, 1989
- 14 Wickström, Ulf, "The plate thermometer - A simple instrument for reaching harmonized fire resistance tests", Fire Technology, Volume 30, No. 2, 1994
- 15 www.volvocars.com/ (2005-11-18)

Appendix A: Background information

Topic: Weights and dimensions of heavy goods vehicles in Europe

Source: "EUROPA", the portal site of the European Union (<http://europa.eu.int/>)

The single market in road freight haulage meant that a number of common rules were needed for vehicles, specifically authorised weights and dimensions for heavy goods vehicles, otherwise Member States might refuse to allow vehicles not meeting their national technical specifications into their territory.

Common technical specifications for the weights and dimensions of lorries and coaches used for international transport were set in 1985 and 1986. In July 1996 the Council of Ministers adopted Directive 96/53/EC which amends the maximum authorised dimensions and applies also to vehicles used in national traffic. Maximum vehicle length was increased to 18,75 m and maximum width to 2,55 m (2,60 m for refrigerated vehicles). The restrictions on height (4,0 m) and weight (40 tonnes) authorised for international traffic were not extended to national traffic.

Topic: Weights and dimensions of semi-trailer combinations in Europe

Source: Backman, Haide and Nordström, Rolf, "Improved Performance of European Long Haulage Transport", TFK Report 2002:6E, TFK Institutet för transportforskning, 2002

In international long haulage transport within the EU, articulated vehicles, usually called semi-trailer combinations, are dominant. Their regular loading capacity, of about 85 m³ and 26 tonnes is provided by a 13,6 m long semi-trailer (the maximum total weight being 40 tonnes or 44 tonnes if the cargo consists of a 40-foot ISO container). Also road trains, consisting of a lorry and a centre-axle trailer, are used. The maximum loading capacity is approximately 96 m³ and 26 tonnes.

The modular concept practised in Sweden and Finland since 1997 is based on the CEN standardised 7,82 m long unit load carrier and the 13,6 m long semi-trailer being the longest single vehicle allowed in EU. The maximum length of this combination of "modules" is 25,25 m.

Topic: Weights and dimensions of heavy goods vehicles in Sweden and Finland

Source: Personal communication with Leif Bäckrud, PLS Flak & Skåp AB, 2005-04-25

Sweden and Finland have an exception from Directive 96/53/EC which allows lorries to be a maximum of 4,50 m high and up to 25,25 m long.

Topic: Dimensions and loading capacity of typical trailers used in Europe
Source: www.lkw-walter.co.uk/

Tilt Trailer (trailer or tautliner) is the standard equipment for the transport of dry, packed and non temperature-sensitive cargo and can be used universally.

Dimensions/loading capacity of a tilt trailer:
Length: 13,60 m
Width: 2,45 m - 2,50 m
Height: 2,50 m - 3,00 m
Up to 34 Euro-pallet spaces (up to 25 tonnes payload)

Other types of equipment (mega trailer, stepframe trailer, road train, delivery van) can be used on certain routes.

Topic: Weights and dimensions of semi-trailer combinations in Europe
Source: www.scania.com/news

According to Directive 96/53/EC, the “normal” European long-haul truck is a 16,5 m tractor-and-semitrailer combination. For container haulage, the 13,6 m semi-trailer can take for example one 40 ft or two 20 ft maritime containers with room to spare. Some types of transport are more suited to rigids with a drawbar or centre-axle trailer, in which case 7,82 m swap-body containers are frequently used.

In most European countries, the gross weight limit for such combinations is 40 to 44 tonnes, usually on five axles, sometimes six.

Due to factors like the need to transport over long distances, tradition and low traffic density, the Scandinavian countries have more generous length and weight regulations. Maximum lengths up to 25,25 m are now permitted in Sweden and Finland with gross weights up to 60 tonnes on seven or eight axles. Individual axle weights have been harmonised with those for European cross-border road freight.

Topic: The load space and the number of unit loads on a freight truck
Source: Information from the section FAQs from G.L. Kayser (<http://www.gl-kayser.de>)

When is my consignment considered “bulky“? When is volume calculated and how?
Freight trucks have maximum permissible load weights which are set by law. For many years, however, transported goods have been getting lighter (light construction methods, aluminium, synthetic materials, micro-technology, etc.) As a result, truck size restrictions have changed. Previously, the weight was the limiting factor; today it is the volume (the load space) of the truck. In the interests of fairness, bulk scales which are independent of volume have been introduced.

One freight truck has an approximate volume of 81,6 cubic meters and a load limit of 24,5 tonnes³. Thus, 1 cubic meter of the load space corresponds to 300 kg of load weight.

³ Values do not take into account the type and construction of the freight truck, and therefore can vary

The following **example** explains the freight-price calculation:

The item: 1 crate (100 cm × 120 cm × 180 cm) = 2,16 cubic meters (volume)

Chargeable freight weight: 2,16 cubic meters × 300 kg = 648 kg

What is a truck load unit? How many load units are there in a truck?

A truck load unit is equivalent to the dimensions of a Euro-palette, i.e. 80 cm × 120 cm.

The number of load units in a truck depends on the construction type and size of the trailer. Small short-distance trucks (7,5 tons) have approximately 15 load spaces. Long distance trucks generally have 33 or 34 load spaces.

Topic: Whether trailers with curtain sides have a solid roof or not?

Source: Personal communication with Bernt Ragnestig, Contrade AB, 2005-08-03

How common is it that trailers covered by a tarpaulin (“curtain sides”) have a solid roof?

It is not very common. Trailers covered by a tarpaulin have usually a roof made from tarpaulin as well. The reason is weight, cost and the accessibility to the cargo. If the roof is made from a solid material it is either made from steel or plastic. Plywood is rare.

Topic: How common are trailers covered by a tarpaulin (“curtain sides”) versus solid type trailers?

Source: Personal communication with Eric Hammar, Sala Kaross AB, 2005-08-10

How common are trailers covered by a tarpaulin (“curtain sides”) versus solid type (“box”) trailers?

Solid type trailers are becoming more and more common in Sweden, trailers covered by a tarpaulin are on their way out from the market. One obvious reason for this is the climate in Sweden. The solid type trailers have either door(s) on the side or at the rear.

Sometimes, tarpaulins are used to cover one of the sides and the other side is solid and not possible to open. However, the situation is different in Europe, where trailers covered by tarpaulins are much more common than in Sweden.

Appendix B: Illustrative photos



Freight trucks on a ro-ro deck, illustrating the short distance between the vehicles and the limited deck height.



A common type freight truck used throughout Europe, where the trailer is covered by a tarpaulin, both on the sides (“curtain sides”) and over the ceiling.



The cargo compartment of the freight truck pictured above. Note that the trailer has no lift at the rear.



A freight truck with a box with solid walls and ceiling, typically used in the Nordic countries.



The inside of the freight truck pictured above.



New cars (Volvo XC90) side by side on the cargo deck of a car carrier. The cars are packed very tight together.

Freight truck fire source

Appendix No: C

Report No: 2006:02

Date: 2006-09-27

Rev. Date:

Scale: 1:75

Sign: MA

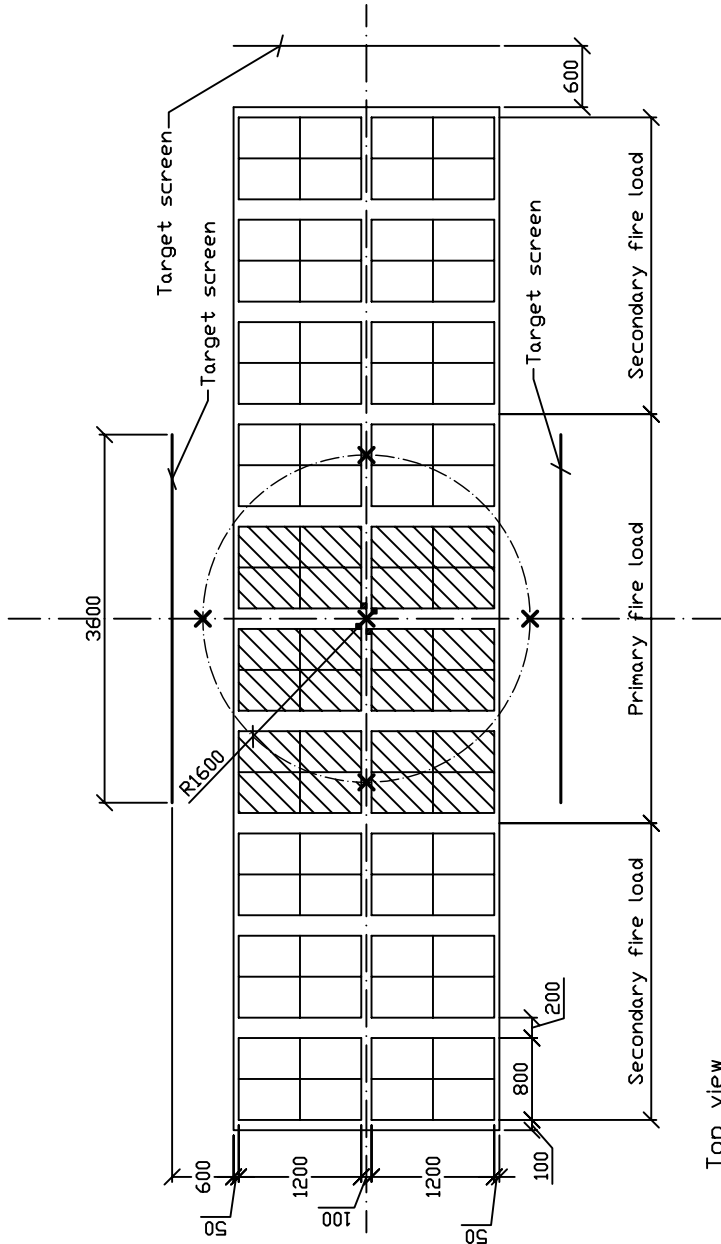

Top view

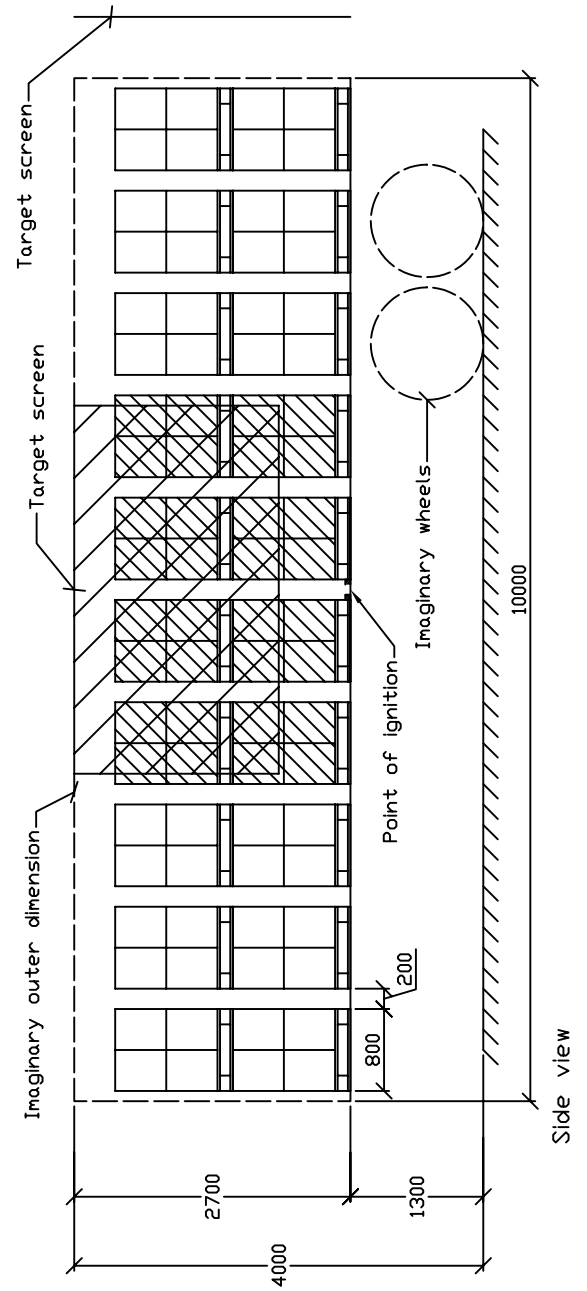

Side view

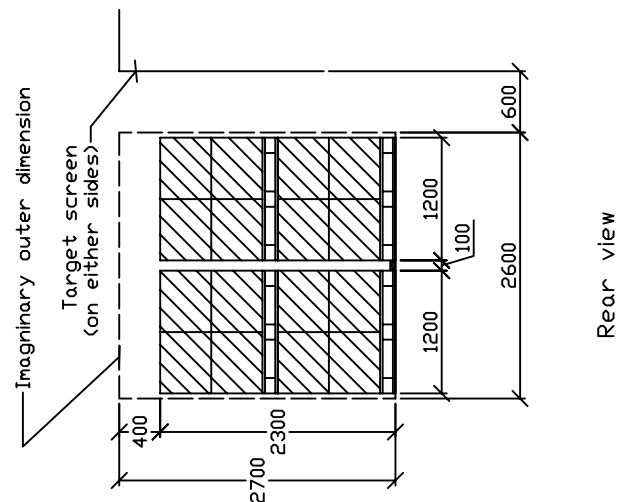

Rear view

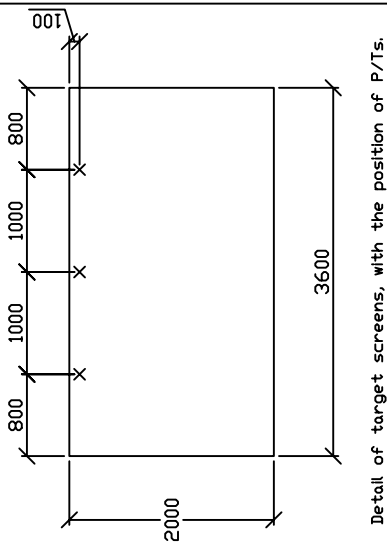

Detail of target screens, with the position of P/Ts.

Detail of the commodity stacks

Wood supports

Appendix No: D

Report No: 2006:02

Date: 2006-09-27

Rev. Date:

Scale: 1:25

Sign: MA

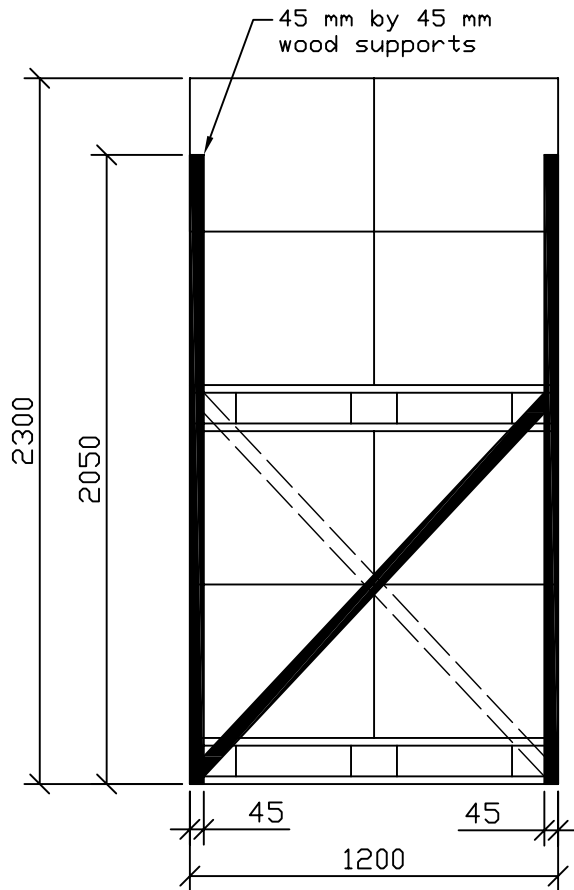

Side view (long side)

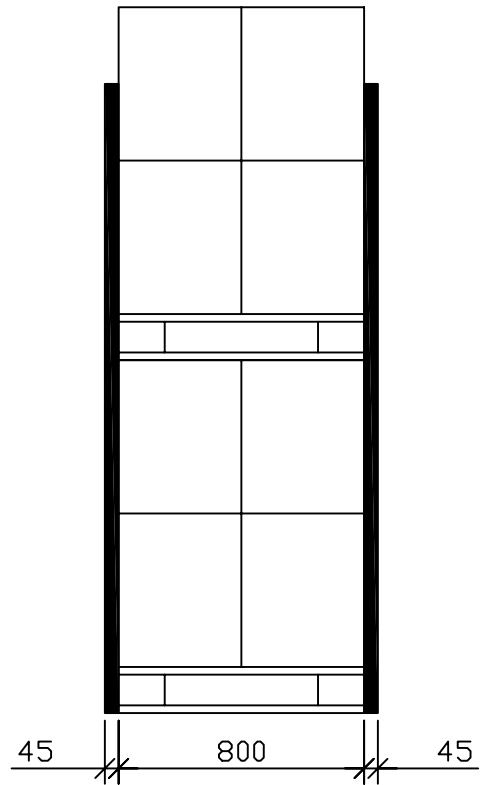

Side view (short side)

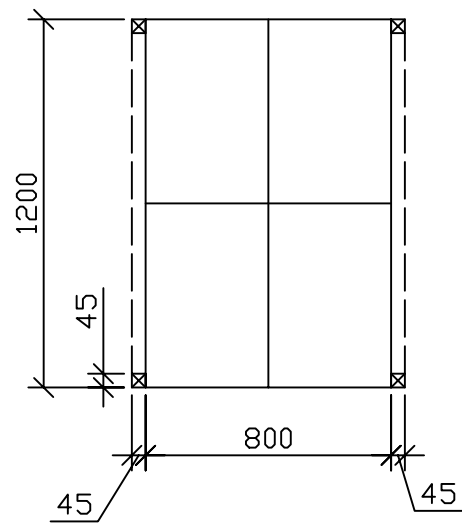

Top view

Passenger car fire source

Appendix No: E

Report No: 2006:02

Date: 2006-09-27

Rev. Date:

Scale: 1:75

Sign: MA

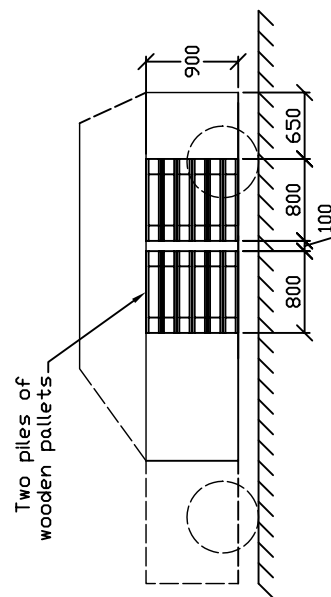
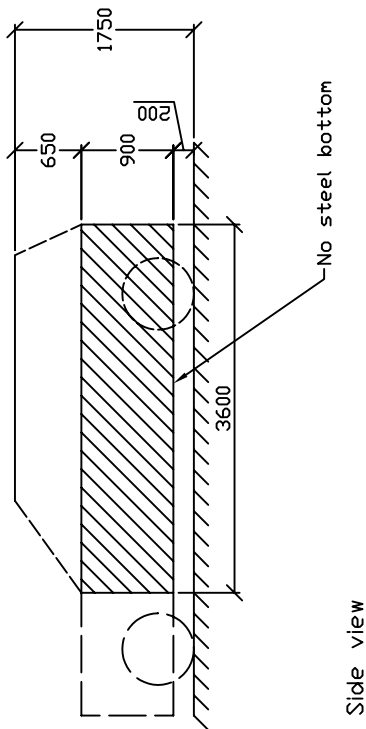
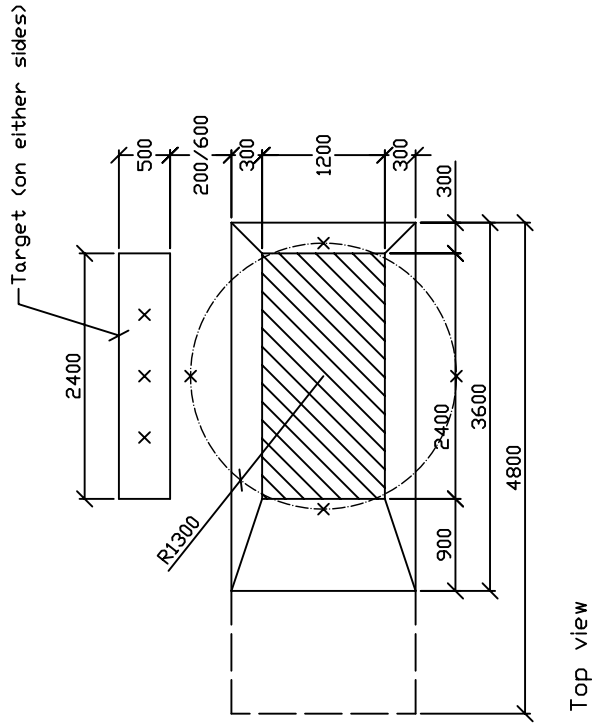
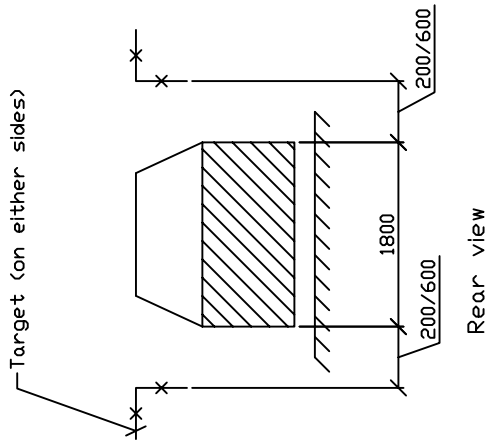

The position of the combustibles

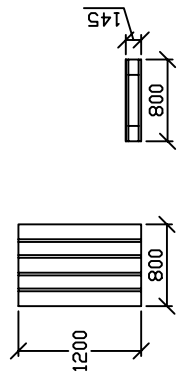

SP Swedish National Testing and Research Institute develops and transfers technology for improving competitiveness and quality in industry, and for safety, conservation of resources and good environment in society as a whole. With Swedens widest and most sophisticated range of equipment and expertise for technical investigation, measurement, testing and certification, we perform research and development in close liaison with universities, institutes of technology and international partners.

SP is a EU-notified body and accredited test laboratory. Our headquarters are in Borås, in the west part of Sweden.

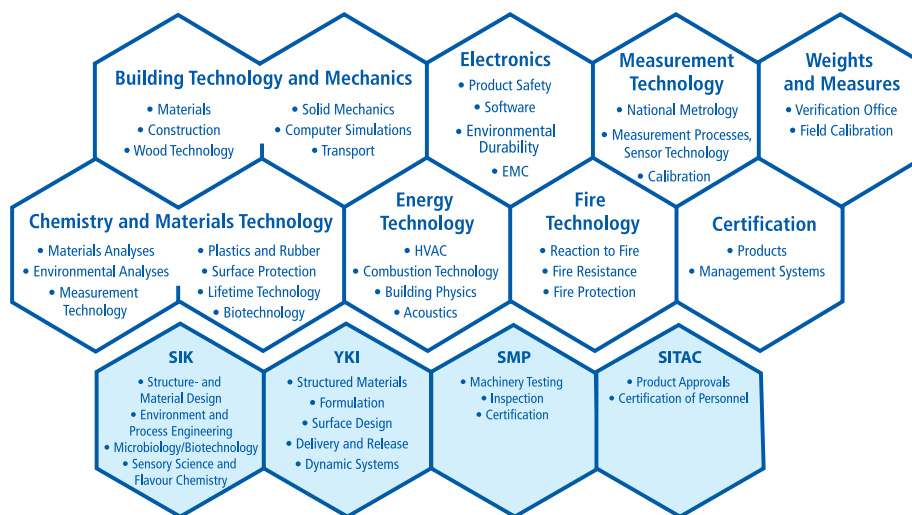

SP is organised into eight technology units and four subsidiaries

SP Fire Technology
 SP REPORT 2006:02
 ISBN 91-85303-81-X
 ISSN 0284-5172



SP Swedish National Testing and Research Institute

Box 857
 SE-501 15 BORÅS, SWEDEN
 Telephone: + 46 33 16 50 00, Telefax: +46 33 13 55 02
 E-mail: info@sp.se, Internet: www.sp.se

A Member of

 **United Competence**