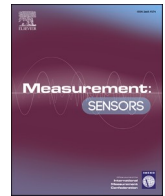

Contents lists available at [ScienceDirect](https://www.sciencedirect.com)

# Measurement: Sensors

journal homepage: [www.sciencedirect.com/journal/measurement-sensors](https://www.sciencedirect.com/journal/measurement-sensors)

## MetSuperCap: Metrology for static and dynamic characterisation of supercapacitors

### ARTICLE INFO

#### Keywords:

Measurement standards  
Measurement uncertainty  
Traceability  
Energy storage  
Supercapacitors  
Circuit models

### ABSTRACT

Unlike Li-ion batteries, supercapacitors (SCs) do not use rare or polluting metals, have a life cycle even two orders of magnitude higher than that of batteries, and do not suffer from either runaway effects or extreme temperatures. They therefore represent an eco-friendly and reliable technology, which can replace batteries or accompany them in high power density applications. To support the growing use of SCs in real and real-time applications, accurate characterization even under operating conditions is required. Furthermore, validated circuitual and software models are needed to identify the SCs behaviour in dynamic applications. Along slower but highly accurate methods, novel quick, traceable, and effective measurement techniques are required to evaluate SCs' State of Charge (SoC) and State of Health (SoH) and to promote the uptake of SC and banks in consumer, energy, transport, aerospace and in many other applications. The MetSuperCap project aims to improve the characterisation of SCs and SC banks by providing an accurate and reliable identification of their parameters in the laboratory and in operation.

### 1. Introduction

Supercapacitors (SCs) represent an environmentally friendly technology that can replace batteries or can be used together with them in higher-power density applications.

The life cycle of SCs is very long (up to hundred times longer than batteries), their charging and discharging limits are not critical. Unlike for batteries, they can operate in a wide temperature range, and do not fear the harsh temperatures of winter. They pose zero thermal runaway risk.

SCs are also environmentally friendly, as they do not contain heavy metals. Hence, they are earning increasing significance in several applications. The development and uptake of SCs has huge market requirements, and long-term progress is needed for their successful advancement and commercialization.

At the same time, SC development is facing challenges such as proper determination of their electrical parameters and establishing industrial standards [1]. Overcoming these technical problems means promoting the use of this eco-friendly technology and reducing the dependence on batteries.

The implementation of SCs into applications asks for reliable tools for the accurate determination of a multiparametric equivalent circuit model (ECM) of a SC, which is not standardised. A clear measurement and identification tool is not within the knowhow of many companies. The same need is substantial for SC banks. A reliable and recognized tool would allow all designers to easily implement SCs into applications.

Applications require frequent monitoring of the SoH and SoC of the supercapacitive components to provide correct feedback to the users and to have a good scheduled maintenance. Therefore, developing rapid and reliable methods of measurement and diagnosis is of great interest for many applications. In specific applications for example, the coexistence of batteries and SCs may lead to a particularly complex Charge

Management Systems (CMS), which are still subjects of research. New models and methods developed for SCs must also prove valid in the presence of distorted waveforms (low power quality). Finally, it should be noted that almost all the studies, standards and guidelines mainly concern Electric Double Layer Capacitors (EDLC); however, hybrid SCs and pseudo-SCs, which are relatively new devices entering the market, must be already considered in perspective, and dedicated guidelines are to be developed for hybrid/pseudo SCs characterisation too.

SCs' metrics are only partially defined by manufacturer guidelines and standards. Moreover, these metrics lack accuracy analysis, and above all, standards for SC banks are lacking. A step forward could be tracing guidelines for the means and methods for accurate characterisation of SCs and SC banks. In addition, validated circuitual and software models are needed to identify the SCs behaviour in dynamic applications. Along slower but highly accurate methods, novel quick, traceable, and effective measurement techniques are required to evaluate SCs' SoC and SoH and to promote the uptake of SCs and banks in consumer electronics, energy, transport, aerospace and in many other applications.

In the project 23IND04 MetSuperCap: Metrology for static and dynamic characterisation of supercapacitors, which is an Industry Joint Research Project of the European Partnership on Metrology (EPM) research funding programme, these gaps will be filled. The project consortium involves twelve partners from seven European countries, including European National Metrology Institutes (NMIs), industrial companies, and academia. It will run from 2024 to 2027.

This paper reports about the objectives, organisation and structure of the MetSuperCap project, its developmental milestones, and some preliminary results achieved in its first months.

The project aims to connect with and impact academia, industry, and normative and regulation bodies. It is building up a stakeholder committee for proper advice and steering during the project life. It

<https://doi.org/10.1016/j.measen.2024.101434>

implements open science practices and FAIR (findable, accessible, interoperable, and reusable) principles and will distribute a periodic newsletter. A project website (<https://www.metsupercap.eu>) provides information and news from the project. The site is linked to social media channels and hosts a newsletter that is released periodically.

## 2. Overall objectives

The overall objective of this project is to support the development of SCs and SC banks by defining the accurate assessment of their parameters, including the ECM parameters, via new traceable measurement methods and validated software. In addition, the project aims to provide rapid techniques for the assessment of the SoC and SoH of SCs and the validation of such techniques in real applications.

The specific objectives of the project are:

1. To develop metrologically traceable methods, including the assessment of uncertainty, for characterising capacitance, resistance, specific power, and energy for SCs of different sizes (from 1 F up to 3000 F, for discharge currents up to 500 A). The developed methods should be suitable for the characterisation of SC banks with maximum instantaneous discharge power up to 25 kW.
2. To develop software/models for identifying relevant parameters for the static and dynamic characterisation of SC and SC bank models. The target error of the developed software/models will be lower than 5 % (for voltages greater than 200 mV). In addition, to define optimised voltage/current waveforms, based on representative SC charging and discharging cycles, for characterising SCs and for validating models by measurement.
3. To develop rapid techniques, including the uncertainty assessment, for measuring the SoC and SoH of SCs accurately.
4. To verify the results for SCs in real conditions by designing and producing two test benches fitted with a measurement system and a measurement procedure to evaluate the actual behaviour of SCs under operating conditions, including battery-SCs hybrid systems. The test benches will also be used for the validation of the outputs of Objectives 1–3 and for the evaluation of at least two applications of SCs in energy systems, (e.g., photovoltaics (PV), electric vehicles (EVs)).
5. To facilitate the uptake of the technology and measurement infrastructure developed in the project by the measurement supply chain, standards developing organisations and end users (e.g., metrology networks, the aerospace, automotive and energy sectors).

## 3. The project approach

### 3.1. Project organisation

The project is organised into 3 technical work packages (WPs), plus one for impact and one for coordination, as summarised in Fig. 1. The three technical WPs address the 4 technical objectives specified in Paragraph II, going beyond the state of the art, as specified thereafter.

### 3.2. Planned advancements

The approach suggested by the standards [2–4] is sometimes relaxed in terms of accuracy of the SC parameters determination. A guide that provides a clear relationship between the instrumentation, the measurement method and the expected uncertainty on the SC parameters would be very useful in this area. Moreover, the literature mainly deals with single EDLC SCs, while for applications the use of SC banks or hybrid SCs is also important. This project will provide clear indications regarding the accuracy in determining the parameters of SCs of different types and banks of SCs.

Multiple approaches for modelling SCs have been presented in the literature [5]. The ECMs are promising due to their strong application

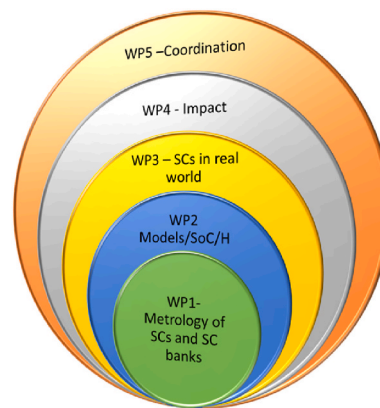

Fig. 1. Project organisation scheme.

value, as they allow the equivalent circuit of the SC to be implemented into complex control systems which can include charge control and the load.

The determination of SoC and SoH allows systems to increase reliability, predictive maintenance, and real-time condition monitoring [6]. Rapid methods are not common but are of great applicative interest. Indeed, the determination of the SoC/SoH requires the use of complex techniques [6] or the use of complex algorithms combined with the device's ECM.

The use of SCs in conjunction with batteries provides undoubted advantages in terms of absorption and return of power peaks which, managed by SCs, improve efficiency, and extend the life of the batteries. There is great interest and research in particular for electric vehicles (EVs) [7]. This type of use requires the development of hybrid charge control systems, which are beyond the state of the art and go beyond a conventional battery management system.

### 3.3. Project time span and partners

The project intends to achieve the expected objectives in a span of 36 months (June 1, 2024–May 31, 2027).

The challenge is faced by a holistic approach provided by the collaboration of 12 partners, listed in Table 1, from 7 European countries, shown in the map in Fig. 2.

## 4. Preliminary results

### 4.1. Equivalent circuit models

The equivalent circuit models (ECMs) are part of the family of models for SCs, which can be summarised with three other typologies:

- fractional models (e.g. Refs. [8,9]);

Table 1

The project partners.

	Organisation full name	Country
INRIM	Istituto Nazionale di Ricerca Metrologica	Italy
CMI	Cesky Metrologický Institut	Czechia
LNE	Laboratoire National de Métrologie et d'Essais	France
RISE	RISE Research Institutes of Sweden AB	Sweden
VSL	VSL B.V.	Netherlands
CRF	Centro Ricerche Fiat S.C.p.A.	Italy
KEYS	Keysight Technologies GmbH	Austria
Novac	Novac Srl	Italy
Pleione	PLEIONE ENERGY GmbH	Germany
POLITO	Politecnico di Torino	Italy
UNIGE	Università degli Studi di Genova	Italy
UTwente	Universiteit Twente	Netherlands



Fig. 2. The European countries involved in the project.

- intelligent models (machine learning or AI, e.g. Ref. [10]);
- electro-chemical models (e.g. Ref. [11]).

The models are used for various purposes: they provide equivalent electrical parameters for the real-time simulation of the SC behaviour, both in static (charging and self-discharging) and dynamic (rapid charging and discharging cycles) conditions, and they provide additional parameters for the determination of SoC and SoH. Therefore, the accuracy in their determination is important, but not easy to obtain, especially because this determination occurs indirectly.

ECMs are particularly suitable for the real-time simulation of the SCs behaviour in complex circuits. Among the ECMs, the three-branch model is one of the most studied. A process for accurately identifying a three-branch equivalent circuit was proposed in Ref. [5]. The process consists of two steps:

- determination of voltage-dependent leakage resistance;
- determination of the equivalent circuit.

4.1.1. Leakage resistance

The leakage resistance  $R_{leak}$  is not a physical parameter but simulates the self-discharge phenomena that occur inside the SC when it is not connected to a load. Self-discharge can be measured by charging the SC at a certain voltage (usually the rated voltage) and reaching a certain charge value. There are not many techniques in the literature.

When a SC is at open-circuit conditions, self-discharge current gradually depletes its charge, resulting in a decline in both Open Circuit Voltage (OCV) and the SoC. Utilising the potentiostatic method, a highly stable DC source is precisely set to match the SC OCV. This DC source is subsequently linked to the cell via a micro-ammeter to measure the current flowing between them. As self-discharge persists, the DC source intervenes, supplying adequate current to uphold the cell at a steady voltage and SoC. As equilibrium is reached between the DC source and the cell, the self-discharge current transitions from internal sourcing to exclusive external supply from the DC source. This transition enables direct measurement of self-discharge current using the micro-ammeter. The leakage resistance behaviour can be obtained from this current behaviour since the OCV remains constant. This method has been successfully tested on batteries [7]. Another method, which has been tested on SCs and proposed in Ref. [5], consists of charging the SC up to a due OCV and leaving the SC connected to a high impedance voltage meter ( $R_{input} \geq 10\text{ G}\Omega$ ) recording the voltage behaviour for a long time. The

procedure has to be repeated by adding an auxiliary resistor  $R_{aux}$  a few hours after the self-discharge is started and recording the voltage behaviour. In this way, one obtains the two trends of the discharge voltage over time  $V_{t1}(t)$  and  $V_{t2}(t)$ , and the two trends of the respective derivatives  $\frac{dV_{t1}(t)}{dt}$  and  $\frac{dV_{t2}(t)}{dt}$ . The leakage resistance voltage behaviour can be obtained as:

$$R_{lea}(V) = R_{aux} \left( \frac{\left. \frac{dV_{t2}(t)}{dt} \right|_{t=t_{aux}}}{\left. \frac{dV_{t1}(t)}{dt} \right|_{t=t_{lea}}} - 1 \right) \quad (1)$$

where  $t_{lea}$  and  $t_{aux}$  represent the time-instants in which the two discharges reach the same voltage. Since the discharge voltage has a monotonically decreasing trend over time, it is immediate to also obtain the  $R_{lea}$  function over time, which has a form of an exponential decay function in increasing form.

For the identification of the equivalent circuit model, it is important to define the initial value of  $R_{lea}$  with one of the two mentioned techniques, or others.

4.1.2. Three-branch ECM

The three-branch ECM provides a good compromise between accuracy and simplicity and is represented in Fig. 3. When identifying the model, only the initial value of  $R_{lea}$  is included, as the model provides the behaviour of the SC for relatively short times (maximum a few hours). The series resistance  $R_i$  can be measured according to established techniques, for example by the change in voltage when current is injected [12]. The parameter identification is achieved through a charging and self-discharging phenomenological approach. The SC is charged with a constant current  $i$  up to the rated voltage (peak). Subsequently, the charging current drops to zero, and the SC undergoes a self-discharging phase. The first branch with parameters  $R_i, C_{i0}$ , and the voltage-dependent capacitor  $C_{i1}$  mainly influences the charging phase within a time span of tens of seconds. The second or delayed branch with parameters  $R_d$  and  $C_d$  mainly influences the initial part of the discharging phase (usually lasting a few minutes), and the third or long-term branch with parameters  $R_l, C_l$  represents the SC behaviour in the latter part of the discharging phase, which usually lasts a few hours. When the three branches reach equilibrium, output voltage  $V_t$  no longer changes if  $R_{lea}$  is not added to the model.

The vector state equation of the circuit can be written as follows:

$$\dot{\mathbf{v}} = \mathbf{A}\mathbf{v} + \mathbf{b} \quad (2)$$

where  $\mathbf{v}$  is the vector representing the state variables ( $V_i, V_d, V_l$ ), which are the capacitor voltages and  $\dot{\mathbf{v}}$  is the time-derivative vector. Matrix  $\mathbf{A}$  and vector  $\mathbf{b}$  can be easily computed by applying Kirchhoff and loop equations, and are functions of the scalar resistances and capacitances quantities  $R_i, R_d, R_l, C_{i0}, C_{i1}, C_d, C_l$ , where the unknowns are six, since  $R_i$  is known.

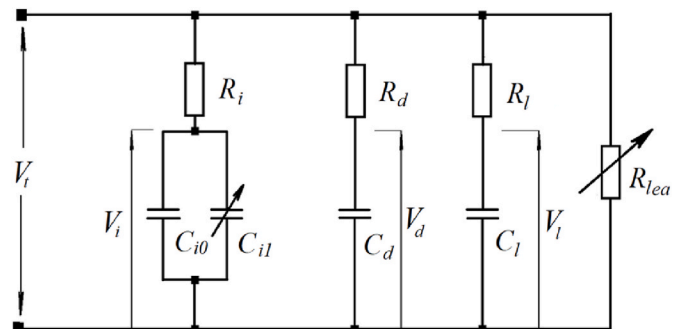

Fig. 3. Representation of the three-branch circuit.

Parameter identification can be done, with high accuracy, through a procedure based on a combination of the circuit state equations with the Conventional Trust Region Reflection (CTRR) optimization algorithm [5]. Starting from trial values, the process identifies the parameters minimising the error compared to the measured OCV behaviour.

Fig. 4 shows the identification of the equivalent circuit of a 60 F SC.

The challenge in developing ECMs is to validate an equivalent model that is reliable, accurate and applicable to a wide range of SC capacitances, including SC banks, taking into account the influencing parameters, like the repeatability of the measurement for identification [13] and, primarily, temperature.

The goal of the MetSuperCap project is to provide at least an ECM that provides discrepancies lower than 5 % between the measured and computed behaviour for a wide range of SCs.

#### 4.2. Traceable electrical impedance spectroscopy

Electrochemical Impedance Spectroscopy (EIS) is a powerful technique for the characterisation of the electrical behaviour of SCs and batteries [14]. The complex impedance spectrum  $Z(f)$  of the SC is measured over frequency  $f$  spanning a range from mHz to kHz and is affected by the SoC and SoH of the SC, and a proper modelling can recover quantitative information of these key performance indicators. As an example, Fig. 5 shows the results of EIS measurement on a 1 F commercial capacitor (EATON mod. HV0810-2R7105-R 1F 2.7V), in the frequency range from 1 to 100 kHz. The effect of the SoC on the impedance spectrum is apparent.

The challenges to be addressed in order to improve the quality of EIS measurements include the analysis of the following topics: i) the parasitic parameters introduced by the connections (the mutual inductance in particular), ii) the limited overall measurement time allotted, iii) the wide frequency range, iv) the need to limit the measurement excitation in the mV range, and v) the small magnitude of  $Z(f)$ , down to the m $\Omega$  range.

Nevertheless, achieving an accurate and traceable measurement is crucial for the proper monitoring of the SC over its life cycle.

The MetSuperCap project is developing techniques for ensuring that EIS measurements are under proper metrological control and traceable to the International System of Units. Techniques being developed include a dedicated short-load correction technique [15], and the use of mutual inductors standards as reliable low-impedance transfer standards in the lower frequency range [15–17].

## 5. Conclusions

The overall objective of the MetSuperCap project is to establish a traceable, consistent, and sound measurement and characterization framework for both SCs and SCs banks. The project is still in its infancy. The results are preliminary and are here reported mainly to better express some of the developmental lines the project will pursue in the forthcoming years.

Connections with stakeholders interested in the project development and results, and possibly in scientific collaborations, are highly welcome. Please contact the project Coordinator, Mauro Zucca ([m.zucca@inrim.it](mailto:m.zucca@inrim.it)) to be included in the mailing list of the project, and receive its periodic Newsletter.

#### Funding statement

This paper has been developed in the framework of the 23IND04 MetSuperCap Project, which has received funding from the European Partnership on Metrology, co-financed from the European Union's Horizon Europe Research and Innovation Programme and by the Participating States.

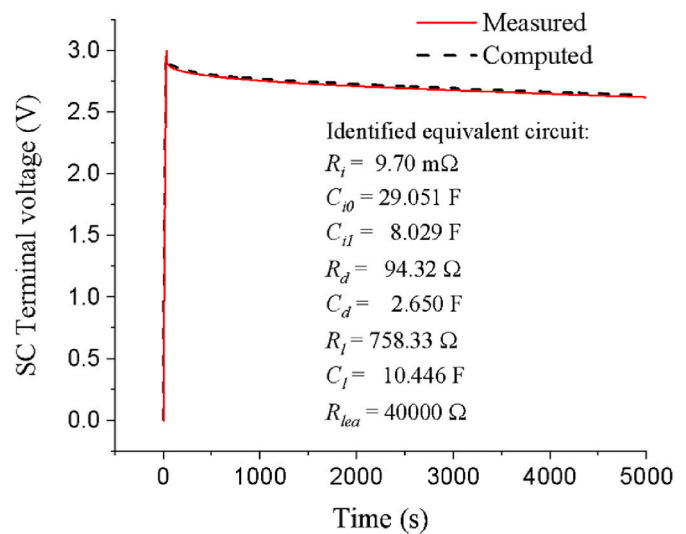

Fig. 4. A 60 F (Eaton TV1840-3R0606-R) SC measured and simulated charge and self-discharge behaviours, when connected to an ITECH IT6015C-80–450 regenerative bidirectional programmable DC power supply. The identified ECM parameters are reported. Discrepancies are less than 40 mV near the peak and lower elsewhere.

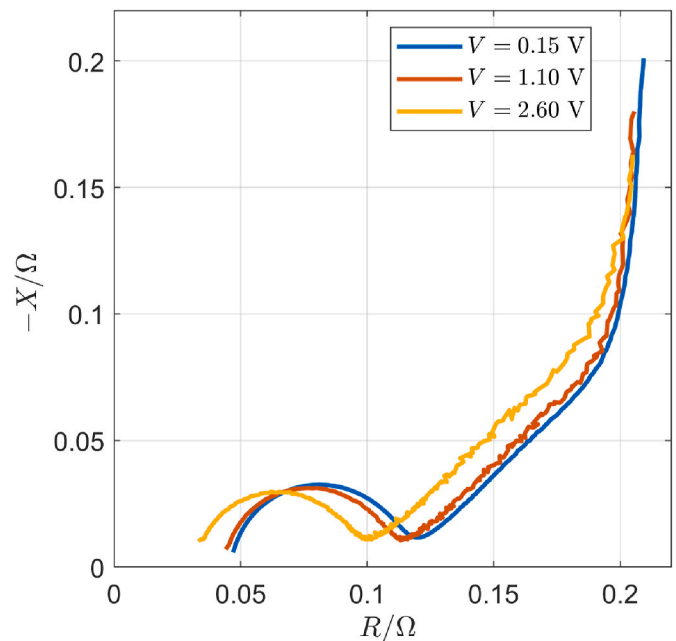

Fig. 5. Measurement of EIS spectra of a 1 F commercial capacitor for different SoC, here represented by the dc charging voltage, plotted as Nyquist ( $R$ ,  $X$ ) diagrams. The frequency ranges from 1 Hz (upper right of the curve) to 100 kHz (bottom left). The impedance meter is under metrological control by using a dedicated short-load correction with calibrated impedance standards.

## References

- [1] S. Huang, X. Zhu, S. Sarkar, Y. Zhao, Challenges and opportunities for SCs, *Apl. Mater.* 7 (2019) 100901.
- [2] EN IEC 62391-1, Fixed electric double-layer capacitors for use in electric and electronic equipment - Part 1: generic specification, CEN-CENELEC (2022). B-1040 Brussels.
- [3] EN 62391-2, Fixed electric double-layer capacitors for use in electronic equipment - Part 2: sectional specification - electric double layer capacitors for power application, CEN-CENELEC (2006). B-1040 Brussels.
- [4] EN IEC 62576, Electric double-layer capacitors for use in hybrid electric vehicles - test methods for electrical characteristics, CEN-CENELEC (2018). B-1040 Brussels.

- [5] M. Zucca, M. Hassanzadeh, O. Conti, U. Pogliano, Accurate parameters identification of a supercapacitor three-branch model, in: *IEEE Access*, vol. 11, 2023, pp. 122387–122398.
- [6] Farshid Naseri, et al., Online parameter estimation for supercapacitor state-of-energy and state-of-health determination in vehicular applications, *IEEE Trans. Ind. Electron.* 67 (9) (2020) 7963–7972.
- [7] N. Al-Zubaidi R-Smith, et al., Fast method for calibrated self-discharge measurement of lithium-ion batteries including temperature effects and comparison to modelling, *Energy Rep.* 10 (2023) 3394–3401.
- [8] Y. Wang, G. Gao, X. Li, Z. Chen, A fractional-order model-based state estimation approach for lithium-ion battery and ultra-capacitor hybrid power source system considering load trajectory, *J. Power Sources* 449 (2020) 227543, <https://doi.org/10.1016/j.jpowsour.2019.227543>.
- [9] N. Bertrand, J. Sabatier, O. Briat, J.-M. Vinassa, Embedded fractional nonlinear supercapacitor model and its parametric estimation method, *IEEE Trans. Ind. Electron.* 57 (12) (2010) 3991–4000, <https://doi.org/10.1109/TIE.2010.2076307>.
- [10] V. Sawant, R. Deshmukh, C. Awati, Machine learning techniques for prediction of capacitance and remaining useful life of supercapacitors: a comprehensive review, *J. Energy Chem.* 77 (2023) 438–451.
- [11] R. Drummond, G. Valmorbidia, S.R. Duncan, Equivalent circuits for electrochemical supercapacitor models, *IFAC-PapersOnLine* 50 (1) (2017) 2671–2676, <https://doi.org/10.1016/j.ifacol.2017.08.551>.
- [12] L. Zubieta, R. Bonert, Characterization of double-layer capacitors for power electronics applications, *IEEE Trans. Ind. Appl.* 36 (1) (2000) 199–205.
- [13] M. Zucca, M. Hassanzadeh, D. Signorino, U. Pogliano, Measurement repeatability of a supercapacitor equivalent circuit parameters, in: 2024 CPEM Conference on Precision Electromagnetic Measurements, 8-12 July 2024. Denver, Co., USA, submitted.
- [14] R. Kötz, M. Hahn, R. Gally, Temperature behavior and impedance fundamentals of supercapacitors, *J. Power Sources* 154 (2) (2006), <https://doi.org/10.1016/j.jpowsour.2005.10.048>.
- [15] J. Medved, A. Cultrera, M. Marzano, V. D'Elia, M. Ortolano, L. Callegaro, Traceable measurements of mutual inductance standards applied to large capacitance simulation in electrochemical impedance spectroscopy, in: 2024 CPEM Conference on Precision Electromagnetic Measurements, 8-12 July 2024. Denver, Co., USA, submitted.
- [16] S. Maslan, High capacitance simulation using mutual inductors, in: 24th IMEKO TC4 International Symposium, 2020, pp. 168–173. Palermo, Italy.
- [17] S. Maslan, H. He, T. Bergsten, S. Seitz, T.P. Heins, Interlaboratory comparison of battery impedance analyzers calibration, *Measurement* 218 (2023) 113176.

Mauro Zucca<sup>a</sup>, Nawfal Al-Zubaidi-R-Smith<sup>b</sup>, Lucie Bartova<sup>c</sup>, Helko van den Brom<sup>d</sup>, Luca Callegaro<sup>a,\*</sup>, Alessandro Cultrera<sup>a</sup>, Lars Fast<sup>e</sup>, Aldo Girimonte<sup>f</sup>, Melika Hassanzadeh<sup>a,g</sup>, Andrea Mariscotti<sup>h</sup>, Athanasios Masouras<sup>i</sup>, Juan Medved<sup>a,j</sup>, Salvatore Musumeci<sup>g</sup>, Giovanna Nicol<sup>k</sup>, Mohamed Ouameur<sup>l</sup>, Gert Rietveld<sup>m</sup>

<sup>a</sup> INRIM- Istituto Nazionale di Ricerca Metrologica, Turin, Italy  
<sup>b</sup> Keysight Technologies GmbH, Linz, Austria  
<sup>c</sup> CMI - Cesky Metrologicky Institut, Brno, Czech Republic  
<sup>d</sup> VSL B.V., Delft, Netherlands  
<sup>e</sup> RISE - Research Institutes of Sweden AB, Borås, Sweden  
<sup>f</sup> Novac Srl, Modena, Italy  
<sup>g</sup> Politecnico di Torino, Dipartimento Energia, Turin, Italy  
<sup>h</sup> Università di Genova, Genova, Italy  
<sup>i</sup> Pleione Energy GmbH, Stuhr, Germany  
<sup>j</sup> Politecnico di Torino, Dipartimento Elettronica e Telecomunicazioni, Turin, Italy  
<sup>k</sup> Centro Ricerche Fiat S.C.p.A., Turin, Italy  
<sup>l</sup> LNE - Laboratoire National de Métrologie et d'Essais, Paris, France  
<sup>m</sup> Universiteit Twente, Enschede, Netherlands

\* Corresponding author.

E-mail addresses: [m.zucca@inrim.it](mailto:m.zucca@inrim.it) (M. Zucca), [nawfal.al-zubaidi-r-smith@keysight.com](mailto:nawfal.al-zubaidi-r-smith@keysight.com) (N. Al-Zubaidi-R-Smith), [lbartova@cmi.cz](mailto:lbartova@cmi.cz) (L. Bartova), [hvdbrom@vsl.nl](mailto:hvdbrom@vsl.nl) (H. van den Brom), [l.callegaro@inrim.it](mailto:l.callegaro@inrim.it) (L. Callegaro), [a.cultrera@inrim.it](mailto:a.cultrera@inrim.it) (A. Cultrera), [lars.fast@ri.se](mailto:lars.fast@ri.se) (L. Fast), [aldo.girimonte@novacsupercap.com](mailto:aldo.girimonte@novacsupercap.com) (A. Girimonte), [melika.hassanzadeh@polito.it](mailto:melika.hassanzadeh@polito.it) (M. Hassanzadeh), [andrea.mariscotti@unige.it](mailto:andrea.mariscotti@unige.it) (A. Mariscotti), [masouras@pleione-energy.com](mailto:masouras@pleione-energy.com) (A. Masouras), [j.medved@inrim.it](mailto:j.medved@inrim.it) (J. Medved), [salvatore.musumeci@polito.it](mailto:salvatore.musumeci@polito.it) (S. Musumeci), [giovanna.nicol@crf.it](mailto:giovanna.nicol@crf.it) (G. Nicol), [mohamed.ouameur@lne.fr](mailto:mohamed.ouameur@lne.fr) (M. Ouameur), [g.rietveld@utwente.nl](mailto:g.rietveld@utwente.nl) (G. Rietveld).